

DS600 Non-Ferrous Double Sheet Detector

Operating Instructions

202177 Revision M

01/14/2020

Prime Controls, Inc.

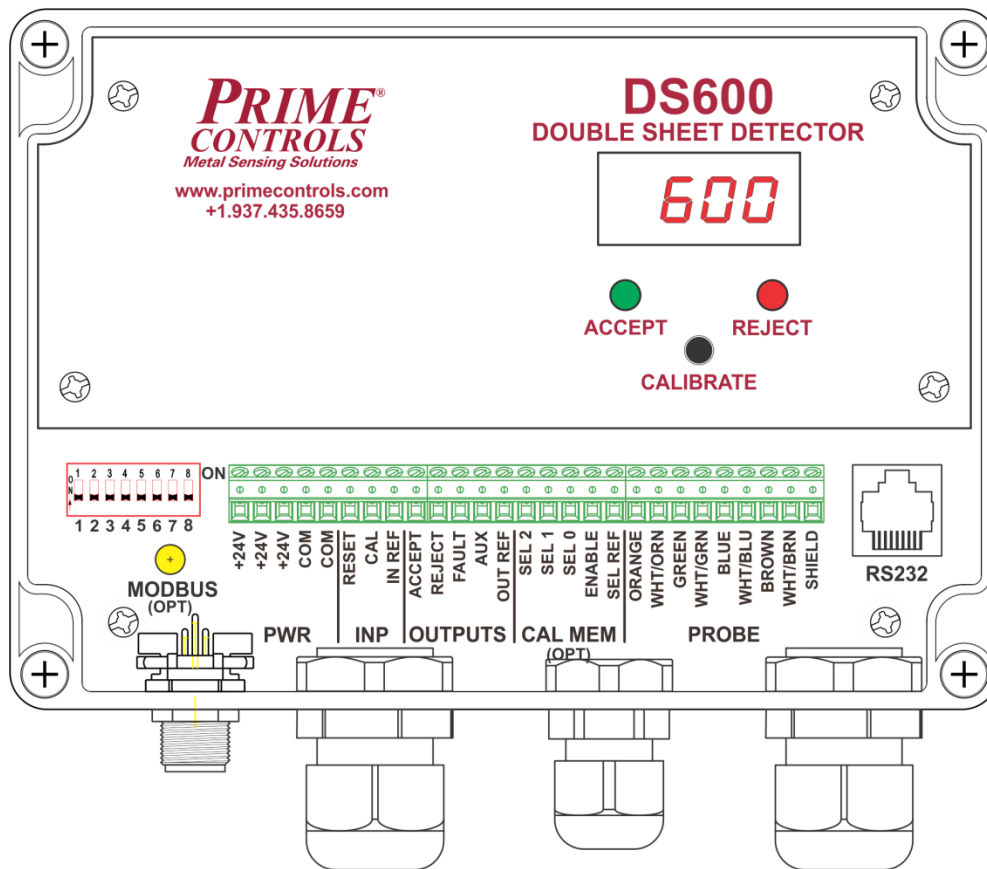

DESCRIPTION

The Model DS600 Double Sheet Detector control module and P80T30P probe comprise a system designed to differentiate a wide range of material thicknesses for non-ferrous metals. This system is especially suited for, but not limited to, the detection of single and double thicknesses of aluminum and 300 series stainless steel (single/double sensing) and detection of missing components (part present sensing).

The control module is housed in an IP65 rated, industrial grade polycarbonate enclosure that can be mounted either inside a control panel or in the open. The P80T30P probe is in the form of a 30mm threaded plastic barrel.

Revision History

Revision	Date	Description	Author
G	2017-01-23	Change bracket part number from BR30AN to BR30PL, added Aluminum distance graph and ranges.	RMC
H	2017-01-31	Added Stainless Steel distance graph and ranges.	RMC
I	2017-02-20	Added ModBus physical and electrical characteristics.	RMC
J	2017-12-21	General clean up and clarification. V1.07 software release.	RMC
K	2019-02-12	Corrected error in LTol default value. V1.10 software release and SW8 reference to Modbus termination. Added wire colors to Table 8. Corrected company address.	RMC
L	2019-03-13	V1.11 software release. Corrected operation of Modbus Read Multiple Registers command (FN06). Increased tolerance for Probe Disconnect detection. Calibrate algorithm enhancement. Reject output off during device turn on.	RMC
M	2020-01-14	Added recommended Htol settings for single point calibration on aluminum and 300 series stainless steel.	JAM

©Prime Controls, Inc.

This document is confidential and proprietary. No part of this document may be disclosed in any manner to a third party without the prior written consent of Prime Controls, Inc.

Table of Contents

1	SYSTEM COMPONENTS.....	1
1.1	Control Module	1
1.2	Probe	2
1.3	Probe Nose.....	2
1.4	Brackets.....	2
1.5	Cables.....	2
1.5.1	High Flex.....	2
1.5.2	Bulk Cable	3
2	INSTALLATION.....	4
2.1	Controller Mounting.....	4
2.2	Probe Mounting and Positioning	4
2.3	Logic I/O Wiring	4
2.4	Input Logic Signals.....	7
2.4.1	IN REF, SEL REF	8
2.5	Output Logic Signals.....	8
2.5.1	OUT REF	9
2.6	Modbus Configuration (DS600PC Only)	9
2.7	DIP Switch Settings	9
3	Operation.....	10
3.1	Power-Up Sequence.....	10
3.2	User Interface	10
3.3	Pushbutton Operation.....	10
3.3.1	Initiating One-Point or Two-Point Calibration	10
3.3.2	Changing Parameter Values.....	10
3.4	Front Panel Display.....	11
3.5	Calibration.....	11
3.5.1	One-point Calibration for Single/Double Sensing.....	12
3.5.2	Two-point Calibration for Single/Double Sensing.....	12
3.5.3	One-point Calibration for Part Present Sensing	13
3.5.4	Two-point Calibration for Part Presence Sensing	13
3.6	Calibration Save and Recall.....	14
3.7	Setup Considerations.....	15

This document is confidential and proprietary. No part of this document may be disclosed in any manner to a third party without the prior written consent of Prime Controls, Inc.

3.8 Gauging Response 15

4 MODBUS COMMUNICATION (DS600PC Only) 18

4.1 Serial Interface..... 18

4.2 Commands 18

4.2.1 Discrete Coil Outputs (000001)..... 19

4.2.2 Discrete Coil Inputs (100001) 19

4.2.3 Register Inputs (300001) 20

4.2.4 Holding Registers (400001) 21

4.3 Calibration Data Backup and Restore..... 22

5 TROUBLESHOOTING..... 23

6 GAUGING SPECIFICATIONS 25

7 ELECTRICAL SPECIFICATIONS 27

8 MECHANICAL SPECIFICATIONS 28

8.1 Controller Drawing 28

8.2 Probe Drawing 29

9 LIMITATIONS AND EXCLUSION OF WARRANTIES..... 30

This document is confidential and proprietary. No part of this document may be disclosed in any manner to a third party without the prior written consent of Prime Controls, Inc.

1 SYSTEM COMPONENTS

1.1 Control Module

The DS600 control module, being sealed, offers flexibility in mounting. Once installed, the system can be quickly and easily brought on-line. Calibration is achieved through the simple press of a push-button switch on the front panel or a remote contact closure connected to the CAL terminal. System status and faults are reported on a four digit numeric display and are signaled through the FAULT output that may be connected to a PLC or system controller.

The **DS600** control module comes in three variations which differ in available features. The three variations are designated **DS600** (basic), **DS600P**, and **DS600PC**. All variants share a common footprint and utilize the P80T30 probe. All models offer the following features:

- Sealed polycarbonate enclosure
- Four digit digital display
- LED indicator for ACCEPT
- LED indicator for REJECT
- User selection of the gauging mode, single/double or part present
- User selection of the response to a no-metal condition, REJECT or ACCEPT
- Front panel pushbutton switch to invoke calibration and parameter adjustment
- Isolated sinking or sourcing logic inputs, CAL and RESET
- Remote initiation of calibration through the CAL input
- Remote reset of the latched REJECT output through the RESET input
- Isolated sinking or sourcing logic outputs, ACCEPT, REJECT, FAULT and AUX
- One and two point thickness calibration
- At least one non-volatile calibration memory
- Single/Double gauging tolerance parameter **HtoL**, adjustable through the front panel
- Part present gauging tolerance parameter **toL**, adjustable through the front panel

The **DS600P** control module offers these additional features:

- “Under” condition sensing with tolerance set through parameter **Ltol**
- Delay of under condition reporting through delay parameter **Udly**
- Up to eight non-volatile calibration memories
- Selection of up to 8 calibration memories through the front panel parameter **SEL** (1-8)
- Logic inputs SEL0, SEL1, SEL2, and ENABLE for selection of the calibration memory from a remote switch or controller

The **DS600PC** control module offers these added features:

- Up to 64 non-volatile calibration memories
- Selection of up to 64 calibration memories through the front panel parameter **SEL** (1-64)
- Selection of the first eight calibration memories through terminals SEL0, SEL1, SEL2 and ENABLE
- Modbus communications through an M12 connector providing access to:
 - The DIP switch settings
 - 64 calibration memories, select and read-back
 - The gauging signal value
 - The four digit display information as text

This document is confidential and proprietary. No part of this document may be disclosed in any manner to a third party without the prior written consent of Prime Controls, Inc.

- The gauging upper and lower tolerance values
- The gauging threshold values (single/double threshold and under/single threshold)
- The no-metal threshold value (no-metal/metal present threshold)
- All calibration values
- Communication statistics
- Specification of the Modbus node number through the front panel parameter **Id**
- Installation of the network terminator through a switch setting

1.2 Probe

The DS600 family currently supports the Prime Controls' 30mm non-ferrous metal P80T30P probe. The connection between the controller and the probe uses an industrial Ethernet cable with 4 twisted wire pairs terminated on one end in a female M12 8 pole connector. The maximum combined length of cables between the probe and controller is 30m.

The probe is in the form of a 30mmx1.5 threaded plastic body 70mm long not including the connector (see page 29).

1.3 Probe Nose

The P80T30P probe may be used with the AC30N Delrin probe nose to protect the sensor nose from potential impact damage. The nose is 2mm thick at the probe face.

1.4 Brackets

The P80T30P probe may be used with the following brackets:

- BR30PL Compliant (spring) mount, plastic
- BR30PA Straight, adjustable point, plastic
- BR30PS Straight, clamp, plastic

1.5 Cables

1.5.1 High Flex

The following high flex cables are available for connecting the P80T30P probe to the DS600 controller:

- CBL600-5 5m high flex cable
- CBL600-15 15m high flex cable

To realize the rated flex life of the cable (10 million cycles), the bend radius of the cable in continuous flex applications must be 150mm (6 inches) or greater. Smaller radii may result in reduced flex life.

Additional cable length may be added to the standard cable length up to 30m total distance from the probe to the controller.

1.5.2 Bulk Cable

Bulk cable may be used between the probe, CBL600-X cable and the controller when additional length is needed up to 30m (100ft) total length. Cable may be ordered as 202324-X, where X is the desired cable length in **feet**. Cables may be spliced using conventional techniques or terminal strips. Color coding should be maintained across any splices to ease installation and repairs if ever necessary. The untwisted, unshielded lead length at the splice should be kept to a minimum. Bulk cable is not rated for continuous flex. If continuous flex is required, please contact Prime Controls.

This document is confidential and proprietary. No part of this document may be disclosed in any manner to a third party without the prior written consent of Prime Controls, Inc.

2 INSTALLATION

2.1 Controller Mounting

The controller is surface mounted by four 0.172" diameter mounting holes located in the corners of the case that are sized for screws as large as #8. They are located on a rectangle 159mm x 121mm (6.26" x 3.58"). The depth of the case at the mounting holes is 0.120". The mounting holes are accessed by removing the four screws that retain the clear cover of the controller.

The Controller can operate in any orientation however, for ease of use, it is best to orient the unit with the display and text right side up. The case is IP65 rated so the unit may be mounted inside or outside of a protective cabinet. Take care that the cable pathways may affect the unit's ability to fully prevent the ingress of liquids. See Mechanical Specifications on page 28 for full details.

2.2 Probe Mounting and Positioning

The P80T30P probe must be mounted using non-metallic materials such as Delrin to insure the mounting hardware does not interfere with the sensing of the target material. No metal should come within half the probe diameter (15mm) of the sides of the probe.

The distance from the P80T30P probe face and the material sample can range from direct contact to as much as ½ inch, depending upon the metal thickness. However, whatever the gap, for proper operation the separation distance must be held constant between gauging and calibration.

2.3 Logic I/O Wiring

The logic inputs and outputs of the DS600 family of controllers are electrically isolated from the controller circuitry. However, the integrity of the isolation and the type of signal (sourcing or sinking) for a particular application are determined by the connections made to the reference lines IN REF, SEL REF, and OUT REF.

For a given signal type, e.g. sourcing or sinking, the reference signals for inputs and outputs are opposite. For sourcing signals, the input reference is connected to common and the output reference is connected to the power supply high side. Conversely, for sinking signals, the input reference is connected to the power supply high side and the output reference is connected to common.

Additional +24V and COM terminals are available on the DS600 family controllers to facilitate appropriate connections to the reference inputs if isolation is not required. If isolation is required, the power supply common and high side of the isolated supply (perhaps power supply powering the PLC connected to the DS600 controller) must be connected to the appropriate reference terminals.

Just as it is possible to mix sourcing and sinking between the INP, OUTPUTS, and CAL MEM groups of signals, it is also possible to mix isolated and non-isolated operation between these same three groups.

In further discussions in this manual, the terms common and +24V will be used to signify power common and high side respectively. These same terms will be used regardless if these potentials are isolated or not from the power used to supply the controller, i.e. if isolation is desired or not.

This document is confidential and proprietary. No part of this document may be disclosed in any manner to a third party without the prior written consent of Prime Controls, Inc.

REFERENCE WIRING: NON-ISOLATED SOURCING I/O

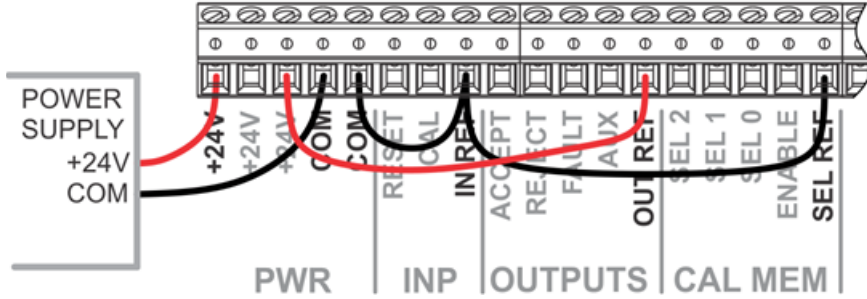

REFERENCE WIRING: NON-ISOLATED SINKING I/O

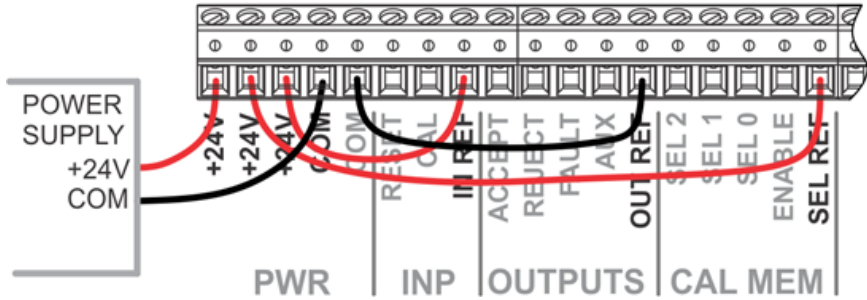

REFERENCE WIRING: ISOLATED SOURCING I/O

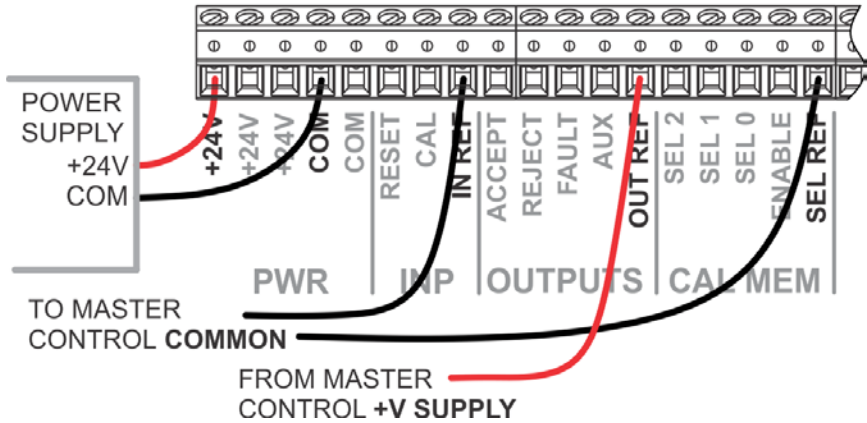

This document is confidential and proprietary. No part of this document may be disclosed in any manner to a third party without the prior written consent of Prime Controls, Inc.

REFERENCE WIRING: ISOLATED SINKING I/O

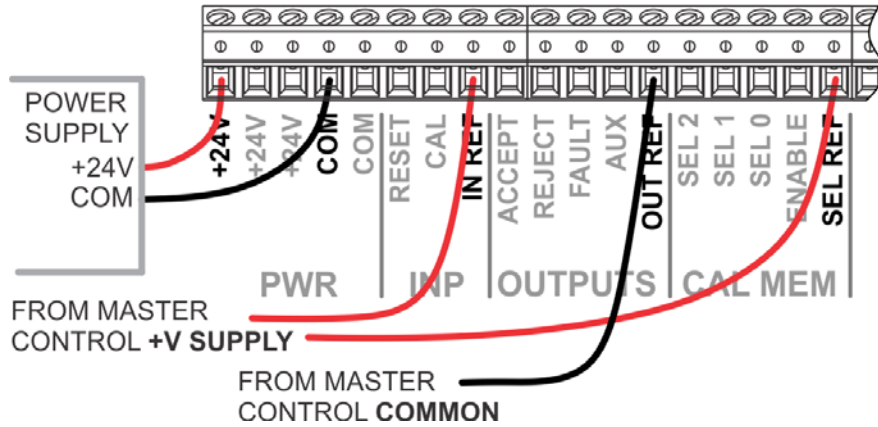

Table 1

Driver Signal Type

Signal Group	Driver Signal Type			
	Non Isolated Sourcing	Non Isolated Sinking	Isolated Sourcing	Isolated Sinking
INP (input)	Controller Common	Controller +24V	Isolated Common	Isolated +24V
CAL MEM	Controller Common	Controller +24V	Isolated Common	Isolated +24V
OUTPUTS	Controller +24V	Controller Common	Isolated +24V	Isolated Common

This document is confidential and proprietary. No part of this document may be disclosed in any manner to a third party without the prior written consent of Prime Controls, Inc.

2.4 Input Logic Signals

The logic inputs to the DS600 family of controllers include the four signals for selecting the calibration memory (SEL0-3 and ENABLE), an external calibration input (CAL) and an output latch RESET signal. All inputs are electrically isolated from the controller circuitry but may optionally be made to share common or power supply voltage with the controller.

All logic inputs may be configured to receive signals from sourcing or sinking drivers. To receive sourcing signals, connect the reference signals (IN REF and SEL REF) to common. To receive sinking signals, connect the reference signals to the +24V power supply voltage.

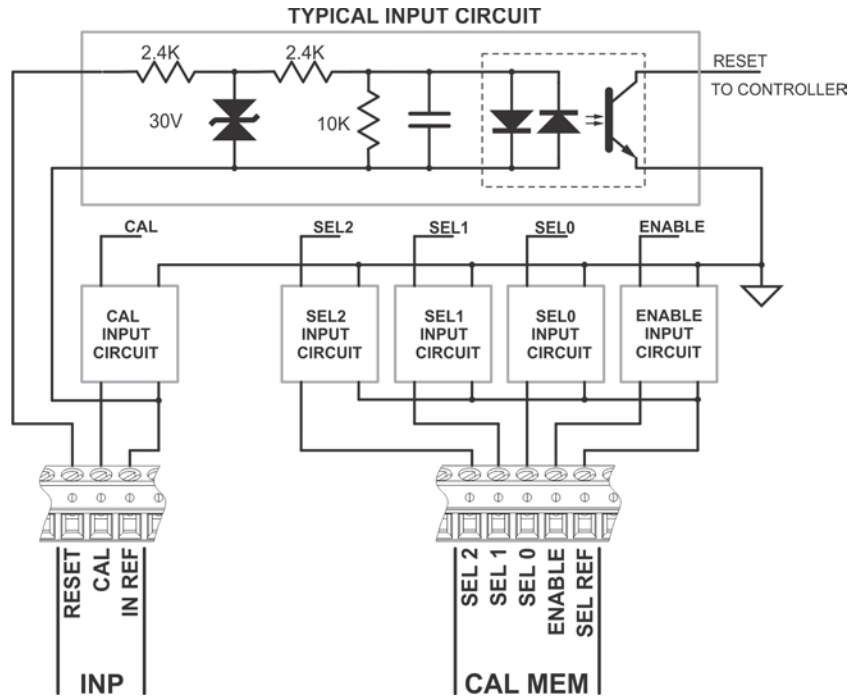

CAL

The CAL terminal provides a means of initiating calibration of the DS600 without having to access the front panel pushbutton. When a pulse is applied to the CAL terminal, high for sourcing, low for sinking, the calibration process is initiated. To be detected by the controller, the pulse must be ON for a minimum of 25 milliseconds. See Calibration section (page 11) for modes of calibration.

RESET

The RESET signal controls the latch feature on the REJECT output signal. If RESET is applied, high for sourcing, low for sinking, the REJECT output simply follows the state of the gauge signal. If RESET is not applied and the gauge signal moves into the reject range, the RESET signal switches to the OFF state and remains there indefinitely until the gauge signal moves out of the reject range and RESET is applied.

This feature allows fast REJECT signals to be captured and held until acknowledged by either a return signal from a controller or a manual reset by an operator.

This document is confidential and proprietary. No part of this document may be disclosed in any manner to a third party without the prior written consent of Prime Controls, Inc.

To avoid the REJECT output being latched in the REJECT state, a jumper must be installed from the RESET terminal to +24V if sourcing I/O is selected or to COM if sinking I/O is selected.

SEL2, SEL1, SEL0, ENABLE

The SEL2-0 and ENABLE terminals are active for the DS600P and DS600PC controllers. These inputs select between one of eight possible stored calibration memories as described in the Calibration section (page 11).

2.4.1 IN REF, SEL REF

The IN REF terminal is connected to either common or +24V based on the type of drivers driving the CAL and RESET inputs. If the drivers are sourcing, then connect IN REF to common. Conversely, if the drivers are sinking, connect IN REF to +24V. Because IN REF is common to both CAL and RESET, the driver connected to each must be of the same type.

The SEL REF terminal is connected to either common or +24V based on the type of drivers driving the SEL0-SEL2 and ENABLE inputs. If the drivers are sourcing, then connect SEL REF to common. Conversely, if the drivers are sinking, connect SEL REF to +24V. Because SEL REF is common to SEL0-2 and ENABLE, the driver connected to each must be of the same type.

2.5 Output Logic Signals

The controller has four logic outputs for reporting the results of the gauging operation and the state of the system. The four outputs are electrically isolated from the internal controller circuitry and the inputs but share a common reference signal: OUT REF. If the outputs are to be sinking, connect OUT REF to common. Conversely, if the outputs are to be sourcing, connect OUT REF to +24V.

Each output is protected from over-voltage by a 30 volt bidirectional transient suppressor and is fused at 50 milliamps by a self-resetting fuse.

ACCEPT

This signal is asserted whenever the gauging logic indicates an acceptable thickness of metal before the probe for double/single sensing, or the acceptable presence of a part for part present sensing. See Tables 5-7 for gauging logic outcomes.

REJECT

The logic of the REJECT signal is implemented to provide failsafe operation. This means the output turns OFF to report a reject condition. Therefore, if the controller loses power, a reject condition is automatically reported. The REJECT output turns OFF if a double is detected for single/double sensing or if a part is found to be missing for part present sensing. Optionally, as determined by the setting of DIP switch 2, a no-metal condition may be reported as a REJECT. See Tables 5-7 for gauging logic outcomes.

FAULT

Like the REJECT output, the FAULT output is implemented to provide failsafe operation. When there is no fault to be reported, the output is ON so that a loss of power to or failure of the controller is more likely to report a fault. The source of faults may be:

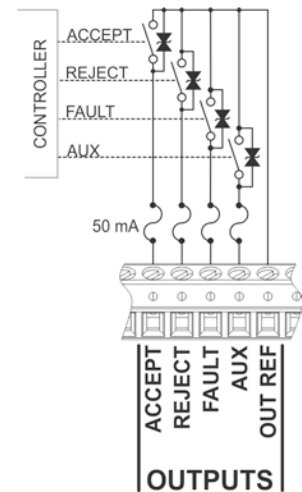

This document is confidential and proprietary. No part of this document may be disclosed in any manner to a third party without the prior written consent of Prime Controls, Inc.

- A disconnected probe
- A failed probe
- An internal controller error

AUX

The AUX output is enabled when switch 3 is ON, to report an UNDER condition, namely, a material condition significantly thinner than the calibrated nominal thickness. Like the REJECT and FAULT outputs, this signal is implemented to provide failsafe operation; the signal turns OFF to report an under condition.

2.5.1 OUT REF

The OUT REF terminal is connected to either common or +24V depending upon the type of output desired for ACCEPT, REJECT, FAULT, and AUX. If sourcing drivers are desired, connect OUT REF to +24V. Conversely, if sinking drivers are desired, connect OUT REF to common. Because OUT REF is common to all outputs, all outputs must be the same type.

See Installation (page 4) of this document for further details.

2.6 Modbus Configuration (DS600PC Only)

Prior to using Modbus communication, the unit’s Modbus ID and Modbus Termination DIP switch (sw8) should be set as required according to the DIP Switch Settings and Changing Parameter Values sections elsewhere in this document.

2.7 DIP Switch Settings

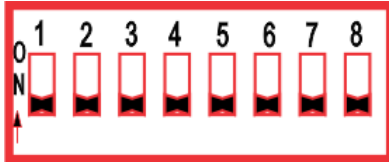

Table 2

SWITCH	FUNCTION	OFF	ON
1	Sensing Type ¹	Single/Double	Part Present
2	Reject on No Metal	No	Yes
3	Aux Output	Disabled	Reports Under
4	Reserved	Set to OFF	
5	Reserved	Set to OFF	
6	Reserved	Set to OFF	
7	Reserved	Set to OFF	
8	Modbus Termination	Disabled	Enabled

¹Changing the state of this switch will prompt for a recalibration.

3 Operation

3.1 Power-Up Sequence

When the system first powers up, the model designation scrolls across the digital display several times identifying the controller as a **dS 600**, a **dS 600P**, or a **dS 600PC**. After displaying the model number, the controller displays the probe ID by flashing alternately, for two seconds, the letters **Prb** and the number **0** indicating the P80T30 probe is connected and functioning. If no probe is connected or the connected probe fails to communicate with the controller, the display flashes alternately the letters **PFI** and the number **1**.

For the DS600P and DS600PC models, a third value is then displayed, the numeric address of the currently selected calibration memory. The display flashes alternately for several seconds, **SEL** and the current calibration memory address.

For all models, if the calibration memory selected at power up holds valid calibration data, the controller transitions to displaying the gauge value, a number from 0 to 100. If the calibration memory does not hold valid calibration data, the controller displays alternately the letters **nEEd** and **CAL** until valid calibration data is saved in the selected memory. Successful execution of the calibration function for the selected memory clears this message and allows the gauge value to be displayed.

If the controller is power cycled while displaying **nEEd** and **CAL**, default calibration parameters are installed at power up and the controller precedes to display the gauge value.

3.2 User Interface

Operation of the DS600, DS600P and DS600PC systems involves calibration and parameter adjustment using the front panel pushbutton, and message interpretation. Calibration may be based on data collected for a single point or on data collected from two points as detailed below under Calibration.

3.3 Pushbutton Operation

The push-button switch on the front panel of the control module serves to initiate the calibration process and to make parameter adjustments for system setup.

3.3.1 Initiating One-Point or Two-Point Calibration

A single, quick press and release of the pushbutton initiates one-point calibration. Two successive quick presses of the pushbutton initiates two-point calibration. See the section on **Calibration** (page 11).

3.3.2 Changing Parameter Values

To view the current value of a parameter, press the pushbutton and hold it for more than 3 seconds until the appropriate parameter identifier (**HtoL**), or if available, (**SEL**), (**Ltol**), (**Udly**) or (**Id**) appears on the digital display. While the pushbutton is pressed, the display cycles through the identifiers with each one shown on the display for one and a half seconds. While the desired parameter identifier is showing on the display, release the pushbutton and the current value of the parameter displays for 5 seconds. To retain the current value of the parameter,

This document is confidential and proprietary. No part of this document may be disclosed in any manner to a third party without the prior written consent of Prime Controls, Inc.

simply allow the 5 second display interval to elapse. The display reverts to displaying the gauge signal with no change to the parameter.

To change the value of a parameter, press the pushbutton and hold it for more than 3 seconds until the appropriate parameter identifier appears on the digital display. While the desired parameter identifier is showing on the display, release the pushbutton and the current value of the parameter displays. Press and hold the pushbutton while the parameter value is displaying and the value increments, first slowly then more rapidly. For more precise control of the value adjustment, simply tap the pushbutton repeatedly until the desired value is displayed. All parameters roll back to their minimum values after reaching the maximum value. To retain the adjusted value of the parameter, simply allow the 5 second display interval to elapse while the new value is displaying. The display reverts to displaying gauge signal strength.

Table 3

Parameter	Full Name	Function	Range [Default]	Controller Type
SEL	Memory Selection	Select calibration memory	1-7 [1]	P only
SEL	Memory Selection	Select calibration memory	1-64 [1]	PC only
HtoL	High Tolerance	Set high tolerance percentage	0-100 [50]	All
LToL	Low Tolerance	Set low tolerance percentage	0-100 [100]	P and PC
toL	High Tolerance (Part Present)	Set high tolerance percentage	0-100 [50]	All in Part Present Mode
Udly	Under Delay	Set “under” reporting delay (hundredths of a second)	0-200 [0]	P and PC
Id	ModBus ID	Set the ModBus Unit ID	1-32 [0] ¹	PC only

¹ Modbus ID defaults to an illegal value requiring the installer to select an appropriate value for their network.

3.4 Front Panel Display

The four digit 7 segment front panel display continuously displays the current gauge value from 0 to 100. A nominal value of 50 is displayed for metal thicknesses equal to the calibration thickness. When not gauging, the display is used to show user prompts, status, and error messages for the controller.

3.5 Calibration

The DS600 supports two modes of calibration, referred to here as one-point and two-point calibration. One-point calibration requires only one sample of material of nominal thickness. Two point calibration requires two samples of the nominal thickness material. Two-point calibration is the most accurate and repeatable calibration method and is recommended.

This document is confidential and proprietary. No part of this document may be disclosed in any manner to a third party without the prior written consent of Prime Controls, Inc.

3.5.1 One-point Calibration for Single/Double Sensing

To perform a single/double one-point calibration:

1. For DS600P and DS600PC controllers, select the desired memory location for the calibration (See **Calibration Save and Recall**, page 14)
2. Place a single thickness of the sample material in front of the probe face.
3. Press and release the CALIBRATE pushbutton once or apply a single momentary signal to the external CAL terminal. The display alternates **CAL** and **Pnt1** until calibration is complete.

The gauging thresholds are computed as an offset from the signal value captured during calibration. The size of the offset is computed as a percentage of the gauge value at Pnt1. The threshold computations are:

$$\text{Single/Double Threshold} = (\text{Cal Pt Value}) \times (1 + \text{Htol}/100)$$

$$\text{Under Threshold} = (\text{Cal Pt Value}) \times (1 - \text{Ltol}/100)$$

The tolerances Htol and Ltol, expressed in percent, may be adjusted through the front panel as parameters **Htol** and **Ltol** respectively. The Htol setting defaults to 50%. However, for greatest reliability in sensing doubles over the thickness range of 0.001" (0.025mm) to 1.14" (3.5mm), the settings specified in the table below are recommended.

<u>Material & Thickness Range</u>	<u>Htol Setting for Double Discrimination</u>
Al .001" (.025mm) through .040" (1.0mm)	40%
Al .041" (1.1mm) through .100" (2.54mm)	20%
Al greater than .100" (2.54mm)	15%
Stainless Steel .001" (.025mm) through 1.40" (35.5mm)	30%

Ltol defaults to 100%. When Ltol is set to 100%, under gauging is disabled.

Under tolerance checking is available in the DS600P and DS600PC only.

3.5.2 Two-point Calibration for Single/Double Sensing

To perform a single/double two-point calibration:

1. For DS600P and DS600PC controllers, select the desired memory location for the calibration (See **Calibration Save and Recall**, page 14)
2. Place a single thickness of the sample material in front of the probe face.
3. Quickly press and release the CALIBRATE pushbutton twice within one second or apply two momentary signals to the external CAL terminal. The display alternates **CAL** and **Pnt1**.
4. Wait for the display to change to **CAL** and **Pnt2** then add a second material sample in front of the probe face and press and release the CALIBRATE pushbutton or apply a momentary signal to the external CAL terminal.

This document is confidential and proprietary. No part of this document may be disclosed in any manner to a third party without the prior written consent of Prime Controls, Inc.

5. If the calibration is successful, the display reverts to displaying the gauge signal and calibration is complete
6. If the material is too thick or if the thickness measured at point 2 is very near to the thickness measured at point 1, the display alternates showing **Lo** and **diFF**. To recover from this condition, follow steps 6 or 7 below.
7. Restart calibration by placing a single thickness sample before the probe and press the CALIBRATE pushbutton once or momentarily assert external CAL. Go to step 3.
8. Wait 30 seconds and the DS600 reverts to its previous state of gauging.

The gauging thresholds are computed as offsets from the first calibration point value. For the single/double threshold, the offset is added to Pt1 placing it between the Pt1 and Pt2 values. The under offset is subtracted from the Pt1 value placing it below the Pt1 value. The size of the offset is computed as a percentage of the distance from the first calibration point to the second calibration point. The upper threshold computation is:

$$\text{Single/Double threshold} = \text{Pnt1} + (\text{Pnt2} - \text{Pnt1}) \times \text{Htol}/100$$

$$\text{Under threshold} = \text{Pnt1} - (\text{Pnt2} - \text{Pnt1}) \times \text{Ltol}/100$$

The tolerances Htol and Ltol, expressed in percent, may be adjusted through the front panel as parameters **Htol** and **Ltol** respectively. The defaults for these tolerances are 15% for Htol and 100% for Ltol. When Ltol is set to 100%, under gauging is disabled.

Under tolerance checking is available in the DS600P and DS600PC only.

3.5.3 One-point Calibration for Part Present Sensing

To perform a part present one-point calibration:

1. For DS600P and DS600PC controllers, select the desired memory location for the calibration (See **Calibration Save and Recall**, page 14)
2. Place the "part missing" condition (the thinner material) in front of the probe face.
3. Press and release the CALIBRATE pushbutton once or apply a single momentary signal to the external CAL terminal. The display alternates **CAL** and **Pnt1** until calibration is complete.

The gauging threshold is computed as an offset from the signal value captured during calibration. The size of the offset is computed as a percentage of the gauge value at Pnt1. The threshold computation is:

$$\text{Threshold} = (\text{Cal Pt Value}) \times (1 - \text{Tol}/100)$$

The tolerance (Tol), expressed in percent, may be adjusted through the front panel as parameter **tol**. The default value for single point calibration is 15%.

3.5.4 Two-point Calibration for Part Presence Sensing

To perform a part present two-point calibration:

1. For DS600P and DS600PC controllers, select the desired memory location for the calibration (See **Calibration Save and Recall**, page 14)
2. Place a sample of the "part missing" material condition in front of the probe face.

This document is confidential and proprietary. No part of this document may be disclosed in any manner to a third party without the prior written consent of Prime Controls, Inc.

3. Quickly press and release the CALIBRATE pushbutton twice within one second or apply two momentary signals to the external CAL terminal. The display alternates **CAL** and **Pnt1**.
4. Wait for the display to change to **CAL** and **Pnt2** then place a sample of the part present condition in front of the probe face and press and release the CALIBRATE pushbutton or apply a momentary signal to the external CAL terminal.
5. If the calibration is successful, the display reverts to displaying the gauge signal and calibration is complete.
6. If the material is too thick or if the thickness measured at point 2 is very near to the thickness measured at point 1, the display alternates showing **Lo** and **diFF**. To recover from this condition, follow steps 6 or 7 below.
7. Restart calibration by placing a sample of the “part missing” condition before the probe and press the CALIBRATE pushbutton once or apply a momentary signal to the CAL terminal. Go to step 3.
8. Wait 30 seconds and the DS600 reverts to its previous state of gauging.

The gauging threshold is computed as an offset from the first point value in the direction of the second point value. The size of the offset is computed as a percentage of the distance from the first point to the second. The threshold computation is:

$$\text{Threshold} = \text{Pnt1} - (\text{Pnt2} - \text{Pnt1}) \times \text{Tol}/100$$

The tolerance (Tol), expressed in percent, may be adjusted through the front panel as parameter **tol**. The default value is 15%.

3.6 Calibration Save and Recall

After successful calibration, the DS600 saves the calibration in non-volatile memory. Model DS600 saves only one calibration dataset. Model DS600P can save up to eight different calibrations, and model DS600PC can save up to 64 different calibrations. Where multiple calibrations can be saved, each saved calibration must be uniquely identified for later retrieval. The identifier is in the form of a number ranging from 1 to 8 for the DS600P and from 1 to 64 for the DS600PC.

The DS600P calibration identifier (1-8) may be specified through the front panel **SEL** parameter or through the signals applied to the SEL2 through SEL0 and ENABLE terminals (See Table 4). Whenever the ENABLE signal is asserted (ON), the selected calibration is determined by the signals applied to the SEL2 through SEL0 terminals. When ENABLE is not asserted (OFF), the selected calibration is determined by the last memory address entered through the front panel **SEL** parameter.

Table 4

SEL2	SEL1	SEL0	MEMORY NUMBER
OFF	OFF	OFF	1
OFF	OFF	ON	2
OFF	ON	OFF	3

This document is confidential and proprietary. No part of this document may be disclosed in any manner to a third party without the prior written consent of Prime Controls, Inc.

OFF	ON	ON	4
ON	OFF	OFF	5
ON	OFF	ON	6
ON	ON	OFF	7
ON	ON	ON	8

The DS600PC calibration identifier may come from any of three sources, 1) the SEL parameter entered through the front panel If ENABLE is not asserted, 2) through the SEL0, SEL1 and SEL2 terminals if ENABLE is asserted, or 3) through the network via the Modbus port if ENABLE is not asserted. Terminals SEL0 through SEL2 always have priority if ENABLE is asserted. When ENABLE is not asserted the selected calibration is the last one entered either

through the front panel or from the network. Thus, if ENABLE is OFF, the latest entry, whether from the front panel SEL parameter or the network, determines the memory selection.

If the selected calibration memory does not contain valid calibration data, the system reports the need for calibration by alternately displaying **nEEd** and **CAL** until a valid calibration is completed or another calibration memory is selected

See **Logic Inputs** (page 6) for electrical implementation of the SEL0, SEL1, SEL2 and ENABLE signals.

3.7 Setup Considerations

For most applications, sensing an “under” condition is not important. Consequently, the factory setting for the under tolerance, **Ltol** (DS600P and DS600PC only) is 100% which disables under detection. When under detection is activated by setting the **Ltol** parameter to a value less than 100, it may be necessary to set the “under delay”, **Udly**, to a value greater than zero.

The under delay is a “delay-on” time for reporting an under condition. The units of the delay setting are hundredths of a second (10 milliseconds). The delay-on to under allows material to be brought into position in front of the probe without reporting an under condition while the part and probe align. The delay range is .01 seconds to 2 seconds.

3.8 Gauging Response

After calibration, the DS600 responds to the probe signal by appropriately indicating the gauging state and activating the control outputs. The response is dependent upon the gauging mode, the position of switches 2 and 3 and the strength of the signal from the probe.

Table 5 shows the response of the DS600 ACCEPT and REJECT LEDs and ACCEPT and REJECT outputs to various gauge signal levels and switch 2 settings for single/double sensing.

Table 6 shows the response of the DS600P and DS600PC ACCEPT and REJECT LEDs and ACCEPT, REJECT, and AUX control outputs to various gauge signal levels and switch 2 settings for single/double sensing.

The single/double sensing mode is intended for metal forming applications where it is imperative that only a single thickness of the sensed material is allowed to pass.

It is worth noting that the REJECT output operates with fail-safe levels. The signal is ON for no reject and off for reject. Thus, if the controller loses power, a reject is reported by default.

For firmware Version 1.11 and later, the REJECT output is also OFF during initialization after power-up, whenever **nEEd Cal** is displayed, and during the calibration process. The ACCEPT output is OFF during these same intervals.

This document is confidential and proprietary. No part of this document may be disclosed in any manner to a third party without the prior written consent of Prime Controls, Inc.

Table 5 – Model DS600 Single/Double Sensing

Gauge Signal	SW 2	ACCEPT LED	ACCEPT Output	REJECT LED	REJECT Output
< No-metal Threshold	OFF	OFF	OFF	OFF	ON
	ON	OFF	OFF	RED	OFF
>= No-metal Threshold	OFF	GREEN	ON	OFF	ON
<= Single/Double Threshold	ON	GREEN	ON	OFF	ON
> Single/Double Threshold	OFF	OFF	OFF	RED	OFF
	ON	OFF	OFF	RED	OFF

Symbols:

< is less than, > is greater than, <= is less than or equal to, >= is greater than or equal to.

Table 6 – Models DS600P and DS600PC Single/Double Sensing

Gauge Signal	SW 2	ACCEPT LED	ACCEPT Output	REJECT LED	REJECT Output	AUX Output*
< No-metal Threshold	OFF	OFF	OFF	OFF	ON	ON
	ON	OFF	OFF	RED	OFF	ON
>= No-metal Threshold	OFF	OFF	OFF	RED	OFF	OFF
<= Under Threshold	ON	OFF	OFF	RED	OFF	OFF
>= Under Threshold	OFF	GREEN	ON	OFF	ON	ON
<= Single/Double Thresh	ON	GREEN	ON	OFF	ON	ON
> Single/Double Thresh	OFF	OFF	OFF	RED	OFF	ON
	ON	OFF	OFF	RED	OFF	ON

* Only if switch 3 ON.

The part present sensing mode may be used to insure that a second component is present on an assembly. A typical application would be to insure that a captive nut is in place on an assembly. The logic of part present sensing is reversed as compared to single/double sensing. Here the stronger signal, indicating more material, is the accepted condition while in single/double sensing the stronger signal indicates the unwanted condition of too much material.

Table 7 shows the response of all DS600 model ACCEPT and REJECT LEDs and ACCEPT, REJECT, and AUX control outputs to various gauge signal levels and switch 2 settings for part present sensing.

Table 7 - Part Present Sensing – All Models

Gauge Signal	SW 2	ACCEPT LED	ACCEPT Output	REJECT LED	REJECT Output
< No-metal Threshold	OFF	OFF	OFF	OFF	ON
	ON	OFF	OFF	RED	OFF
>= No-metal Threshold	OFF	OFF	OFF	RED	OFF
<= Part Present Threshold	ON	OFF	OFF	RED	OFF
> Part Present Threshold	OFF	GREEN	ON	OFF	ON
	ON	GREEN	ON	OFF	ON

This document is confidential and proprietary. No part of this document may be disclosed in any manner to a third party without the prior written consent of Prime Controls, Inc.

4 MODBUS COMMUNICATION (DS600PC Only)

4.1 Serial Interface

The Modbus serial protocol is a Master-Slave protocol where the DS600PC operates as a Modbus slave that communicates with the master when a request is received. The DS600PC operates in RTU transmission mode with its electrical interface in accordance with the EIA/TIA-485 standard in a two-wire (half duplex) configuration at 38400 bps. The unit has a male M12 connector for connecting it to the bus. The interface is electrically isolated from all other power and returns connected to the DS600PC unit.

Table 8 – Modbus M12 Connector Pinout

Pin	Function	Wire Color	Comment
1	No Connect	Brown	Unused
2	No Connect	White	Unused
3	Common	Blue	Isolated Modbus return
4	D0	Black	RS-485 A/A'
5	D1	Grey	RS-485 B/B'

4.2 Commands

Table 9 – Modbus Command Codes – DS600PC

Command Code	Message Type	Meaning
1	Read coils	Bit reads from addresses 0000nn
2	Read discrete inputs	Bit reads from addresses 1000nn
3	Read holding registers	Register reads from addresses 4000nn
4	Read input registers	Register reads from addresses 3000nn
5	Write single coil	Bit writes to addresses 0000nn
6	Write single register	Register writes to addresses 4000nn
15	Write multiple coils	Bit writes to addresses 0000nn
16	Write multiple registers	Register writes to addresses 4000nn

This document is confidential and proprietary. No part of this document may be disclosed in any manner to a third party without the prior written consent of Prime Controls, Inc.

4.2.1 Discrete Coil Outputs (000001)

Coil Address	Name	Meaning
000001	Left Green LED	Left Green LED (Accept LED)
000002	Left Red LED	Left Red LED (Accept LED)
000003	Right Green LED	Right Green LED (Reject LED)
000004	Right Red LED	Right Red LED (Reject LED)
000005	Net Green LED	Network Green LED
000006	Net Red LED	Network Red LED
000007	Accept	Accept Output
000008	Reject	Reject Output
000009	Fault	Fault Output
000010	AuxOut	Auxiliary Output
000011	NetCalReq	Calibration request
000012	NetHighReq	Force outputs high
000013	NetLoReq	Force outputs low

4.2.2 Discrete Coil Inputs (100001)

Coil Address	Name	Meaning
100001	DIPSw1	DIP Switch 1 Input
100002	DIPSw2	DIP Switch 2 Input
100003	DIPSw3	DIP Switch 3 Input
100004	DIPSw4	DIP Switch 4 Input
100005	DIPSw5	DIP Switch 5 Input
100006	DIPSw6	DIP Switch 6 Input
100007	DIPSw7	DIP Switch 7 Input
100008	DIPSw8	DIP Switch 8 Input
100009	InputReg 1	Calibrate pushbutton
100010	InputReg 2	External Calibration Input
100011	InputReg 3	Reset input
100012	MemSelReg0	Mem Sel 0 input
100013	MemSelReg1	Mem Sel 1 input

This document is confidential and proprietary. No part of this document may be disclosed in any manner to a third party without the prior written consent of Prime Controls, Inc.

Coil Address	Name	Meaning
100014	MemSelReg2	Mem Sel 2 input
100015	MemSelReg3	Mem Sel Enable input

4.2.3 Register Inputs (300001)

Register Address	Name	Size	Meaning
300001	Variant Code	Byte	Variant code for the controller
300002	Network ID	Byte	ModBus network ID
300003	Display Average	Byte	Average gauge value on the display
300004	Receiver Value	Byte	Scaled receiver signal level (8 bits)
300005	Receiver 10 bit value	Word	Raw receiver signal level (10 bits)
300006	Fault register	Byte	Fault codes
300007	Cal data block size	Byte	Calibration data block size

This document is confidential and proprietary. No part of this document may be disclosed in any manner to a third party without the prior written consent of Prime Controls, Inc.

4.2.4 Holding Registers (400001)

Register Address	Name	Size	Meaning
400001*	Consolidated coils	Word	Copy of bits 000001 through 000013
400002*	Consolidated discr ins	Word	Copy of bits 100001 through 100015
400003*	System variant code	Byte	Copy of 300001
400004*	Network ID	Byte	Copy of 300002
400005*	Display Mode (0, 1, or 2)	Byte	0 => 4 digits, 1 => alternating, 2 => scroll
400006*	Display Text	6 Words	Currently displayed text
400012*	Display average (0-100)	Byte	Copy of 300003
400013*	Receiver value (8 bit)	Byte	Copy of 300004
400014*	Receiver value (10 bit)	Word	Copy of 300005
400015*	Fault register	Byte	Copy of 300006
400016	Gage upper tolerance	Byte	Gage high threshold % offset above cal pt1
400017	Gage lower tolerance	Byte	Gage low threshold % offset below cal pt1
400018	Controller Gain	Byte	Controller digital gain pot setting
400019	Probe Gain	Byte	Probe digital gain pot setting
400020	Gage high threshold	Byte	Boundary between accept and high reject
400021	Gage low threshold	Byte	Boundary between under and accept
400022	Gap threshold	Byte	Boundary between under and no-metal
400023	Frequency	Word	Current operating frequency
400024	DS600 active slot no	Byte	Memory slot number of current cal data
400025	Cal data access slot	Byte	Targeted calibration memory for read or write
400026	Cal data array	20 Words	Calibration data array transfer buffer
400046	Total bus message cnt	Word	Modbus total message count since reset
400047	Handled message cnt	Word	Modbus successful messages since reset
400048	CRC error cnt	Word	CRC error occurrences since reset
400049	Exception response cnt	Word	Exception responses since reset
400050	No response msg cnt	Word	Messages not responded to since reset
400051	Character overrun cnt	Word	Character overrun errors since reset
400052	NAK response cnt	Word	NAK responses since reset
400053	Busy response cnt	Word	Busy responses since reset

This document is confidential and proprietary. No part of this document may be disclosed in any manner to a third party without the prior written consent of Prime Controls, Inc.

* These registers are read-only. Writing to these registers will result in a “Bad Address” error.

4.3 Calibration Data Backup and Restore

Any or all of the 64 calibration datasets may be transferred to an external device via Modbus. The data is transferred as a block without identification of individual data items within the block. Valid datasets, i.e. those that have been generated by the calibration process, include a CRC word that allows the dataset to be validated if restored at a later time.

To retrieve or restore a calibration dataset via Modbus, the slot address (1 to 64) must first be written to register 400025 and then the data either read from or written to locations 400026 through 400042. If a restored calibration dataset is either corrupted or was not generated by the calibration process, the message **nEEd Cal** flashes on the DS600 display when that dataset is selected for use. The **nEEd Cal** message is cleared when calibration is initiated and the display reverts to showing the current gauge signal once complete.

5 TROUBLESHOOTING

Should trouble develop, proceed as follows:

1. Check +24V input power to the controller.
2. Verify the integrity of all electrical connections to the unit.
3. If the unit powers up, initializes and the indicators show a response to changes in metal at the probe face but the outputs are not changing, check that the RESET input is set to unlatch and that the IN REF input is properly wired for the type of RESET input. If the RESET input is not used, connect it to common if IN REF is connected to +24V or connect it to +24V if IN REF is connected to common.
4. On the DS600PC the ModBus ID must be configured to enable Modbus communication.
5. Use the diagnostic messages displayed and Table 10 to identify an appropriate corrective action

For further information on service assistance, contact Prime Controls, Inc., 4528 Gateway Circle, Dayton, Ohio, 45440 USA. Phone +1(937)435-8659. Have the model number and serial number of the unit available to expedite service.

Table 10 - Messages – All Models

Message	Full Name	Meaning
Power On Messages		
dS 600	Model DS600	System Identification as DS 600
dS 600P	Model DS600P	System Identification as DS 600P
dS 600PC	Model DS600PC	System Identification as DS 600PC
Prb #	Probe #	Probe identification value
SEL #	Select #	Memory Selection value
Parameter Value Messages		
SEL	Select	Memory selection input parameter
Htol	High Tolerance	High Tolerance input parameter
Ltol	Low Tolerance	Low Tolerance input parameter
Udly	Under delay	On-delay to reporting an under condition
tol	Tolerance	Part Present Tolerance input parameter
Id	Identification	ModBus Identification value (address)

This document is confidential and proprietary. No part of this document may be disclosed in any manner to a third party without the prior written consent of Prime Controls, Inc.

Message	Full Name	Meaning
Calibration Messages		
CAL Pnt1	Calibrate Point 1	The controller is actively measuring a single metal condition or the first of a two point calibration
CAL Pnt2	Calibrate Point 2	The controller is waiting for the double metal condition to be placed in front of the probe and a momentary press of the Calibrate button to finalize the two-point calibration
Lo Diff	Low Difference	There was an insufficient difference in the detected metal between a single and double condition during a two-point calibration
Error Messages		
not ConF	Not Configured	The controller requires factory service
ConF Err	Configuration Error	The controller requires factory service
need CAL	Need Calibration	The selected calibration memory location is empty. Run a calibration for this memory or select a memory that has been calibrated.
Lo ##	Low value	Receiver amplitude too low. Recalibrate. Check all probe wiring.
Hi ##	High value	Receiver amplitude too high. Recalibrate, Check all probe wiring.
PFlt ##	Probe Fault #	Unable to get probe ID. Probe is not properly connected or has failed
PrB Cnct	Probe Cnct	Probe Connection Error. Verify probe cabling and connections to the controller
Err 1	Error 1	Digital Pot pass-thru fault – Factory Service Required
Err 2	Error 2	DIP sw input shift register fault – Factory Service Required
Err 3	Error 3	ID digit driver fault – Factory Service Required
Err 4	Error 4	LED driver fault – Factory Service Required
Err 5	Error 5	Three digit display driver fault – Factory Service Required
Err 6	Error 6	Display LSD driver fault – Factory Service Required
Factory Service Messages		
not ConF	Configure	Configuration input parameter (factory use)
Conf n	Set Configuration	Confirm configuration selection n (factory use)
SyS	System Type	System type input parameter (factory use)
Freq	Frequency	Frequency input parameter (factory use)

This document is confidential and proprietary. No part of this document may be disclosed in any manner to a third party without the prior written consent of Prime Controls, Inc.

6 GAUGING SPECIFICATIONS

Aluminum:

Gauge Thickness Range:	0.001" to 0.150" 25.4µm to 3.81mm
Probe to Sample Gap:	Direct contact to 0.500" Direct contact to 12.7mm

300 Series Stainless Steel:

Gauge Thickness Range:	0.001" to 0.165" 25.4µm to 4.19mm
Probe to Sample Gap:	Direct contact to 0.500" Direct contact to 12.7mm

Graphs 1 and 2 show the expected difference in displayed gauge value between single and double thicknesses of aluminum and 300 series stainless steel samples, respectively, following two-point calibration. This information is valid for probe gaps (distance from probe face to gauge sample) ranging from no gap up to 0.5 inches (12.7mm). In operation, the gap distance used during gauging must be the same as the distance used during calibration.

A displayed difference of at least 15 counts between the single and double condition is ideal and provides for reliable single/double detection over minor variations in material properties, probe alignment, gap distance variations, and material temperature. Should this difference be less than 15 counts, such as when gauging materials thicker than 0.125", take extra care to insure consistent probe gap distance, probe to material alignment, and minimize temperature variations to less than 20°C/36°F in the gauged material between calibration and operation.

For thicker samples where the single/double difference drops to as low as 10 counts, reliable double detection can still be realized if external variables such as temperature and probe gap are more tightly controlled.

For reliable double detection, especially with thicker aluminum materials, the temperature of the material during operation should not vary substantially from the temperature of the material during calibration.

Graph 1 – Aluminum Gauging – All Models

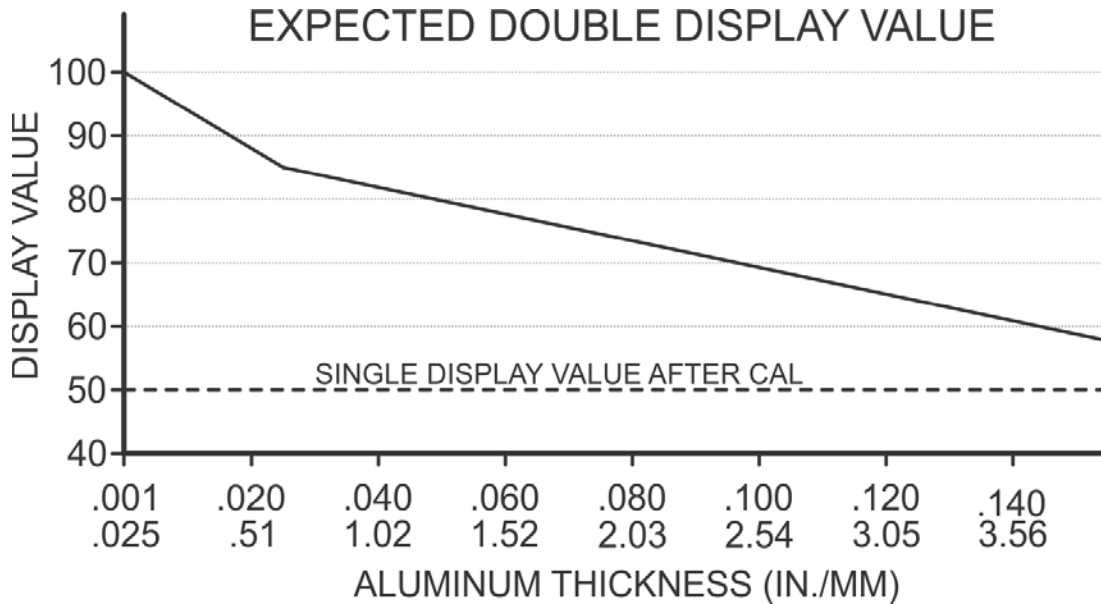

Graph 2 – 300 Series Stainless Steel Gauging – All Models

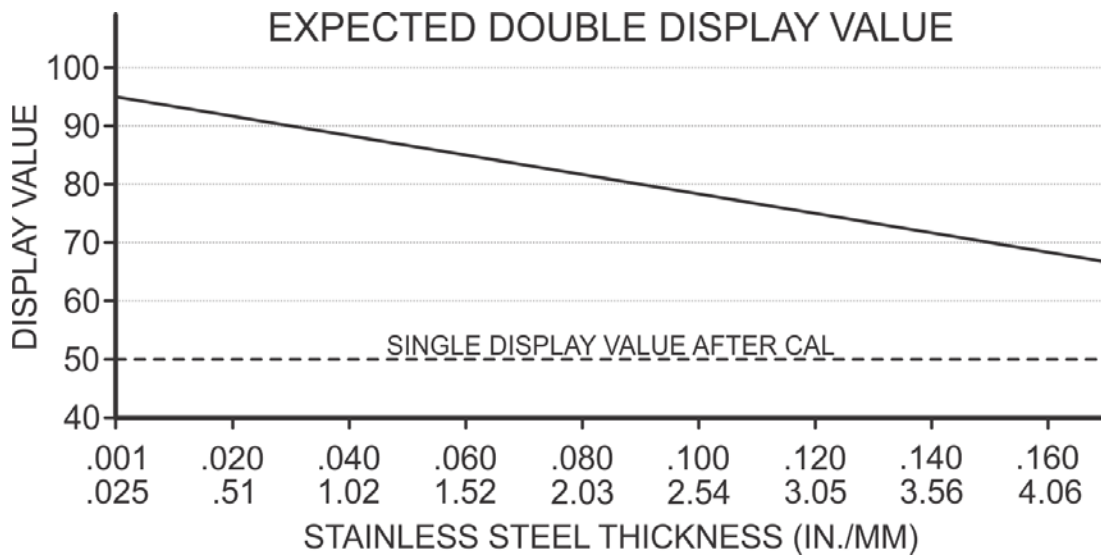

This document is confidential and proprietary. No part of this document may be disclosed in any manner to a third party without the prior written consent of Prime Controls, Inc.

7 ELECTRICAL SPECIFICATIONS

Supply Voltage:	24 volts DC plus or minus 10%
Supply Current:	200 mA plus sourcing output load
Inrush Current at Startup:	300 mA
CAL and RESET Max Input Voltage:	30V
CAL and RESET Input Impedance:	5K ohms
IN REF Max Voltage:	26 Volts
SEL REF Max Voltage:	26 Volts
OUT REF Max Voltage:	26 Volts
Sourcing Outputs:	On voltage: OUT REF (See I/O Wiring, p. 4) Off voltage: 0 volts Max current: 50 mA
Sinking Outputs:	On voltage: 0 volts Off voltage: OUT REF (See I/O Wiring, p. 4) Max current: 50 mA
Output Overload Protection:	50 mA self-resetting thermal fuse
Input and Output Transient Protection:	30 volt transient absorber.
Probe Cable Length:	30m maximum
NET input and NET output:	Isolated RS485 2W, 38400 baud, RTU mode Users selectable termination

This document is confidential and proprietary. No part of this document may be disclosed in any manner to a third party without the prior written consent of Prime Controls, Inc.

8 MECHANICAL SPECIFICATIONS

8.1 Controller Drawing

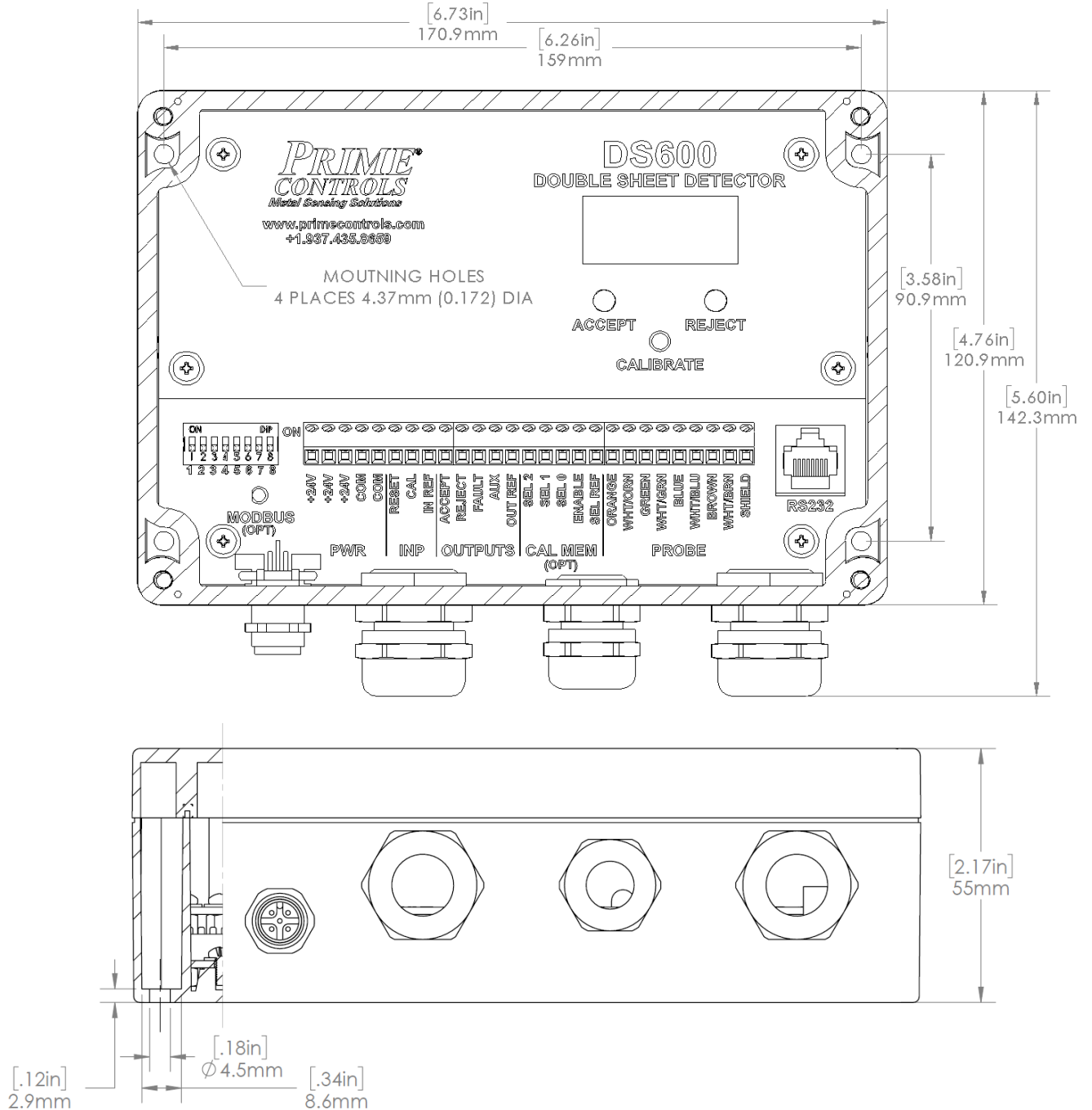

Cross sections showing controller size and mounting hole details.

This document is confidential and proprietary. No part of this document may be disclosed in any manner to a third party without the prior written consent of Prime Controls, Inc.

8.2 Probe Drawing

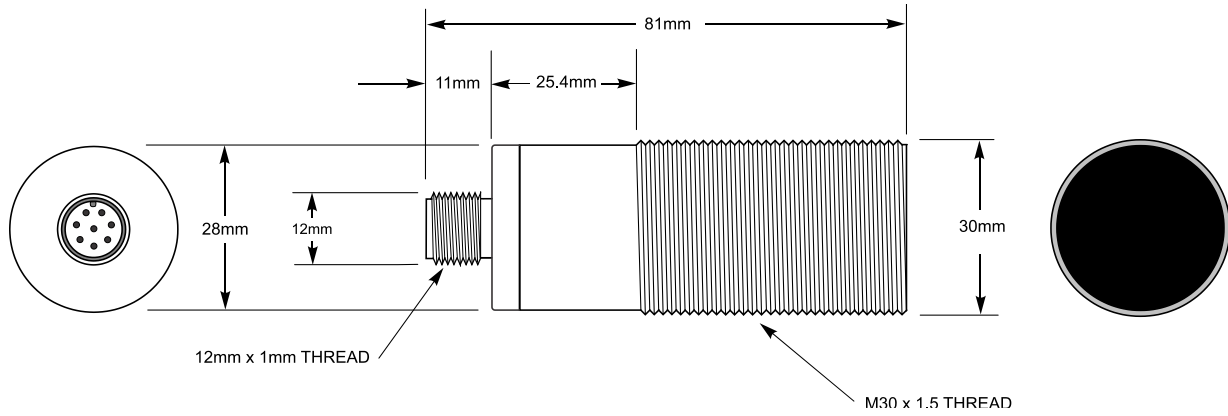

This document is confidential and proprietary. No part of this document may be disclosed in any manner to a third party without the prior written consent of Prime Controls, Inc.

9 LIMITATIONS AND EXCLUSION OF WARRANTIES

All goods purchased from PRIME CONTROLS, INC. shall be free from defects in materials, design and workmanship under normal conditions of use for one year from the date of shipment. THIS WARRANTY IS THE SOLE WARRANTY AND IS EXPRESSLY IN LIEU OF ALL OTHER WARRANTIES, EXPRESS OR IMPLIED, INCLUDING BUT NOT LIMITED TO ANY IMPLIED, WARRANTY OF MERCHANTABILITY OF FITNESS FOR A PARTICULAR PURPOSE. THE LIABILITY OF PRIME CONTROLS TO ANY PURCHASER SHALL BE LIMITED EXCLUSIVELY TO THE COST OF REPLACEMENT OR REPAIR OF DEFECTIVE PARTS, AND SHALL NOT INCLUDE LIABILITY FOR ANY DIRECT, CONSEQUENTIAL OR INCIDENTAL DAMAGES WHATSOEVER, WHETHER FORESEEN OR UNFORESEEN, INCLUDING BUT NOT LIMITED TO LOST PROFITS, LOST SALES, OR INJURY TO PERSONS OR PROPERTY.

This document is confidential and proprietary. No part of this document may be disclosed in any manner to a third party without the prior written consent of Prime Controls, Inc.