

OPERATING INSTRUCTIONS

MODEL SD220/SD230 TRISENSE SHELL/TAB/LEAK DETECTOR

2022.02.09

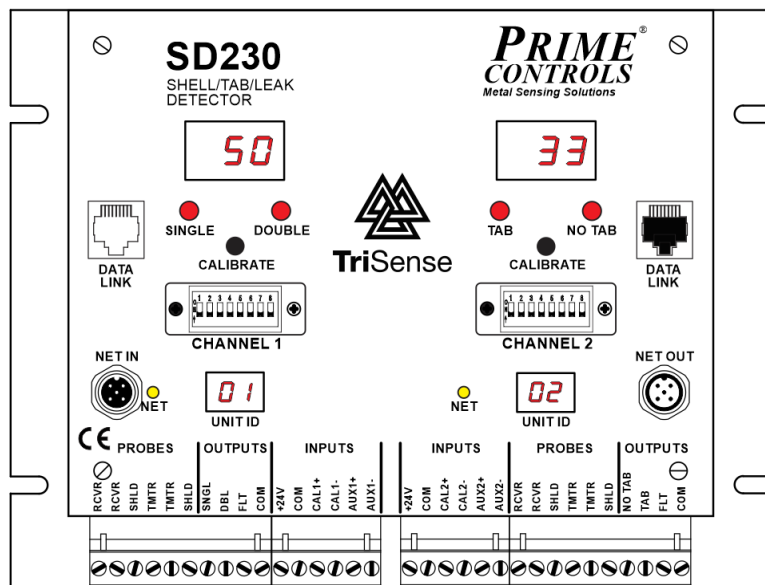
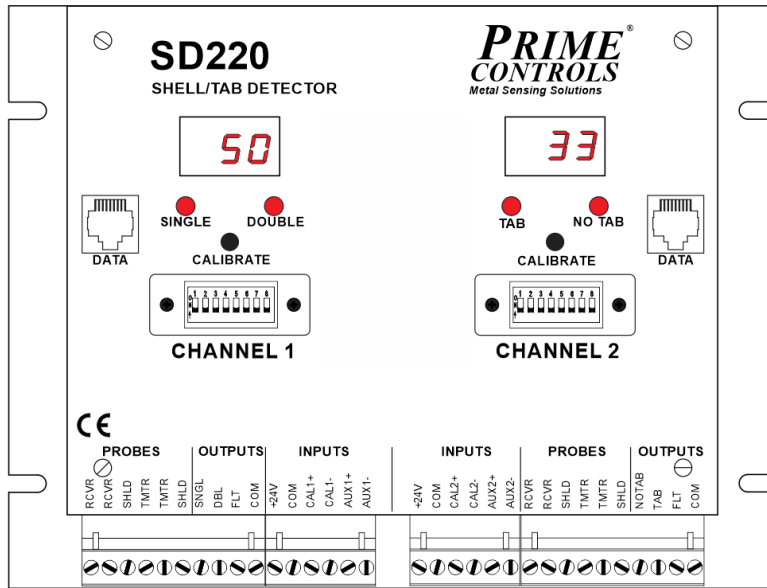

ORIGINAL INSTRUCTIONS

Table of Contents

DESCRIPTION	1
Control Module	1
Calibrate Pushbutton Operation	1
Probes.....	2
OPERATION	2
Calibration	2
Fault Message Interpretation	3
INSTALLATION	4
Safety.....	4
Power.....	4
Hazardous Locations.....	4
Installing the Probes.....	4
Mounting the Control Module	4
Wiring the Control Module	5
Setting Switch Options	6
Selecting Metal Types.....	7
Set Sinking or Sourcing Outputs	7
Set Outputs for Failsafe or Compatibility	8
Enable or Disable Tab Profiling.....	8
Setting Options Through the Front Panel	8
Set TriSense Mode (SD230 Only)	8
Adjusting the Tolerance.....	9
Set Display Direction.....	9
Set Quick Calibration Changeover	10
Parameter Ranges.....	10
Parameter Value Ranges	10
Special Functions.....	10

Remote Calibration	11
Quick Calibration Changeover	11
Determining Firmware Version	12
MAINTENANCE	12
TROUBLESHOOTING	12
DECOMMISSIONING.....	13
DOCUMENT APPLICABILITY	13
ELECTRICAL SPECIFICATIONS	14
SD220/SD230 CONTROL MODULE DIMENSIONS.....	15
SD230/TRISENSE WIRING DIAGRAM	16
SD220/SD230 PROBE WIRING RECOMMENDATIONS	17
SD220/SD230 OUTPUT SIGNALS	18
SUMMARY OF DIFFERENCES BETWEEN SD200 AND SD220/SD230	19
SD200 TO SD220/SD230 MIGRATION.....	19
MODBUS NETWORK (SD230 Only)	21
Description	21
Installation.....	21
Setup	21
Cabling.....	22
SD230/Pro-Face System Cabling.....	22
SD230 To Pro-Face HMI Cable	22
EthernetIP Gateway Interconnect	23
ModBus Entities	25
Discrete Coil Outputs (000001) (Read/Write)	25
Discrete Coil Inputs (100001) (Read Only).....	27
Register Inputs (300001) (Read Only).....	28
Holding Registers (400001) (Read/Write)	33
LIMITATION AND EXCLUSION OF WARRANTIES.....	36
NAME PLATE INFORMATION	36

EC DECLARATION OF CONFORMITY37
UKCA DECLARATION OF CONFORMITY.....38

DESCRIPTION

The SD220 Double Shell/Missing Tab Detector and the SD230 Double Shell/Missing Tab/Leak Detectors for conversion press applications are rugged but sensitive dual channel instruments designed specifically to detect and report missing blanks or double blanks at the infeed to a conversion press and to detect and report ends that exit the press without tabs. The SD220 and SD230 units are identical except the SD230 supports Modbus Networking capability and TriSense functionality.

A complete system for one lane of a press comprises a control module housed in an aluminum enclosure and four probes. One transmitting and receiving probe pair senses doubles at the press input while the second transmitting and receiving pair senses the presence or absence of tabs at the press output.

The SD230 when operating in TriSense mode, the controller interfaces to optional LH200 Light Leak Detector and SL100 LED Strobe Lamp to add leak detection capability to the controller. Status and configuration data passes through the controller's Modbus interface through a serial link to the LH200 to provide complete control and monitoring of the Light Leak Detection functionality.

Multiple SD230 units, with or without TriSense functionality may be interconnected through a Modbus network. See the Modbus Networking section (page 21) for details.

Control Module

The control module allows for fast and easy setup and for quick diagnosis of system errors or problems. Setup is achieved through the simple press of a push-button switch or an external contact closure. Faults are reported on digital displays on the control module and through FAULT outputs that may be connected to a PLC or system controller.

The DOUBLE, SINGLE, NO TAB, TAB and FLT (fault) outputs may be switch selected as sinking or sourcing drivers. An eight position DIP switch, accessible on the front panel, allows the installer to select a number of operational options as described in the installation section of this document.

The AUX inputs provide a means to switch between two different setups, such as sensing steel shells and sensing aluminum shells, without recalibrating or changing the DIP switch settings. This input may also be used in TriSense mode to provide flash detection.

When the unit first powers up, if probes are properly connected, the digital displays indicate the operational mode of the unit, i.e. whether set up for sensing **Aluminum**, **Steel**, or **Aluminum on Steel** by displaying the characters "**Al**", "**St**" or "**AS**" for a period of approximately two seconds. Which mode comes up is determined by the setup of the unit through the DIP switches and the state of the AUX input. See setup (page 6) later in this document.

Calibrate Pushbutton Operation

The push-button switches on the front panel of the control module serve to initiate the calibration process and to make adjustments for system setup including: set the TriSense mode (**tr**) (SD230 only),

adjust the gauge tolerances (“**tL**”), set the display option to invert the digital display (**do**), and set the function of the AUX input (“**AU**”).

To initiate calibration, simply press the appropriate pushbutton and release it within 3 seconds.

To view the current value of a parameter, press the pushbutton and hold it for more than 3 seconds until the appropriate parameter identifier (“**tr**”, “**tL**”, “**do**”, or “**AU**”) appears on the digital display. After the parameter identifier appears, release the pushbutton and the current value of the parameter displays for 5 seconds. To retain the current value of the parameter, simply allow the 5 second display interval to elapse. The display reverts to displaying the gauge signal.

To change the value of a parameter, press the pushbutton and hold it for more than 3 seconds until the appropriate parameter identifier appears on the digital display. After the parameter identifier appears, release the pushbutton and the current value of the parameter displays. Press the pushbutton while the parameter is displaying and the value increments, first slowly then more rapidly. For more precise control of the value adjustment, simply tap the pushbutton repeatedly until the desired value is displayed. All parameters roll back to their minimum values after reaching the maximum value. To retain the adjusted value of the parameter, simply allow the 5 second display interval to elapse. The display reverts to displaying signal strength.

Probes

The SD220/SD230 controllers may be used with any P15 or P70 series two wire probes or with older model three wire probes including AV, AY, AZ, AZA, and CB probes. When used with older three wire probes, the white wire in the probe cable is not used and must remain disconnected.

OPERATION

Operation of the SD220/SD230 Double Shell/Missing Tab Detector involves only two processes, calibration and fault message interpretation. These processes are described below.

Calibration

Calibration requires the following steps:

1. Stop the press in the dwell portion of the cycle with a single end between the infeed probes and a good tabbed end between the discharge probes.
2. Observe that no error conditions are being reported on either display of the SD220/SD230 control module.
3. Press and release the CALIBRATE pushbutton on channel 1 of the SD220/SD230 control module and observe the SINGLE and DOUBLE LEDs flashing alternately and “**CAL**” on the digital display. If the calibration is successful, the LED flashing stops in less than three seconds and the digital display shows a number between 48 and 52.

If the display flashes alternately “**CAL**” and “**Lo**”, the calibration was unsuccessful due to insufficient signal at the receiving probe. This can be an indication that the probes are too far apart or that the unit is not set to the appropriate frequency for the material being sensed, e.g. frequency set to aluminum when steel ends are present. If the display flashes alternately “**CAL**” and “**Hi**”, the receiver signal is too strong indicating nothing between the probes.

If the calibration problem is not resolved and the calibration switch is not pressed again within 30 seconds, calibration mode is aborted and the previous calibration values are reinstated.

4. Press the CALIBRATE pushbutton on channel 2 of the SD220/SD230 control module and observe the TAB and NO TAB LEDs flashing alternately and “**CAL**” on the digital display. If the calibration is successful, the LED flashing stops in less than 3 seconds and a number between 28 and 33 is displayed.

If the display begins to alternately flash “**CAL**” and “**Lo**”, the calibration was unsuccessful due to insufficient signal at the receiving probe. This can be an indication that the probes are too far apart or that the unit is not set to the appropriate frequency for the material being sensed, e.g. frequency set to aluminum when steel ends are present.

If the calibration problem is not resolved and the calibration switch pressed again within 30 seconds, calibration mode is aborted and the previous calibration values are reinstated.

If both channels calibrate successfully, calibration is complete. The calibration process may also be initiated through an external switch or signal controlling the CAL+ and CAL- inputs to the SD220/SD230. Activation of this input performs the same function as pressing the CALIBRATE push-button switch for the corresponding channel.

Fault Message Interpretation

The SD220/SD230 monitors the probe connections on a continuous basis and reports what it detects to be disconnected or malfunctioning probes. The probe faults are reported as follows:

Alternately flashing “**PR**” and “**1**” - transmitter probe disconnected or failing

Alternately flashing “**PR**” and “**2**” - receiver probe disconnected or failing

Alternately flashing “**PR**” and “**3**” - both probes disconnected or failing

During calibration:

Alternately flashing “**CAL**” and “**Lo**” indicates a low signal at the receiving probe.

Alternately flashing “**CAL**” and “**Hi**” indicates the signal at the receiver is too strong, likely no end between the probes.

The SD220/SD230 performs extensive self-diagnostics at power up and more limited diagnostics while running. Most fatal faults, if not involving the display subsystem, are reported on the digital displays through the alternate flashing of “**Err**” and “**nnn**” where “**nnn**” is a one to three digit number indicating

the source of the fault. These faults are not field repairable and require the change-out of the control module.

Any detected fault causes the FLT output to be turned OFF until the fault is cleared.

INSTALLATION

Installation comprises four basic steps: 1) Installing the probes, 2) Mounting the control module, 3) Wiring the unit, and 4) Setting system options. Each of these steps is further expanded below.

Safety

Power

When performing installation, service or maintenance on the equipment, disconnect power to the machine and Lock Out/Tag Out the power in accordance with your plant standard operating procedures.

Hazardous Locations

This equipment is suitable for operation in non-hazardous locations only.

Installing the Probes

1. Mount the double detecting infeed probes, one above and one below the centerline of the track carrying the ends into the press. The probes must be positioned such that they are centered on the can end during the dwell portion of the press cycle. In the vertical, the track should run midway through a gap of approximately 5/8 inch (16mm) between the probes.
2. Positioning of the tab detecting probes is more critical than the positioning of the infeed probes. For most tabbed ends, the optimum position for the probes is above and below the ring of the tab, not centered on the rivet. Centering on the rivet only works on some older tab designs where the tab formed a ring around the rivet. If positioning of the tab sensing probes is uncertain, contact Prime Controls for help.

Mount the tab detecting probes, one above and one below the tabbed ends as they are carried on the track from the press. The probes must be positioned such that they are centered on the tab ring during the dwell portion of the press cycle. In the vertical, the track should run midway through a gap of approximately 5/8 inch (16mm) between the probes.

3. Run the probe cabling through conduit back to the cabinet housing the control module. *Do not run the sensor cables through conduit carrying high level or noisy signals.*

Mounting the Control Module

Mount the control module on the back panel of a grounded industrial enclosure. Insure that the mounting screws make good electrical contact between the module housing and the grounded control enclosure back panel. Alternatively, connect a grounding wire to one of the mounting screws to provide a ground. In the case of grounding the controller to a panel door, insure that the door is properly

grounded in accordance with best practices. The footprint is 8.25 inches (210 mm) by 6.25 inches (159 mm) with mounting slot locations on a rectangle 7.625 inches (194 mm) in the horizontal and 4.0 inches (102 mm) in the vertical. See drawing at the end of this document. To avoid an electrical hazard while operating the unit inside the enclosure, all live parts in the enclosure shall be IP2X or better.

If the control module is mounted external to an enclosure or on an enclosure door, an adequate cover must be installed over the exposed connectors to achieve IP4X protection or better. The door must be permanently grounded and good electrical contact between the control module and grounded door must be achieved.

Wiring the Control Module

Probe cable routing must follow best practices to isolate the sensitive probe signals from sources of interference such as AC mains, variable frequency drives, digital switching signals and other high current, high voltage or high speed signals. Power wiring to the unit should also follow best practices to isolate the low-voltage DC power from AC mains and other high voltage or high current wires. Where paths must cross, their intersection should be perpendicular. All wires should be terminated with a wire ferrule to prevent wire breakage and shorting due to stray conductors contacting nearby connections.

1. Connect +24V DC power between both sets of the +24V and COM terminals of the control module. The left and right side modules are electrically independent and must be powered independently. The two +24V terminals are NOT internally connected. The supply must be capable of delivering 0.250 amps continuously with a startup surge of 0.500 amps for 2 milliseconds.
2. Connect the double detecting transmitter probe wires to the two TMTR terminals on the channel 1 side of the control module and the double detecting receiving probe wires to the two RCVR terminals on the channel 1 side of the control module. The probe connections are not polarized. Connect the shield wires to the terminal labeled SHLD.

Though both the transmitting and receiving probes are identical, it is preferred practice to choose the transmitting probe as the one that will remain farthest from the track as it moves and stretches.

On retrofit installations where older three wire probes are installed, cut back and do not connect the third (white) wire. If in doubt about which wires to use, measure the resistance between the wires in pairs, and then use the pair that produces the highest resistance reading (typically 24 ohms).

3. Connect the tab detecting transmitter probe wires to the TMTR terminals on the channel 2 side of the control module and the tab detecting receiving probe wires to the two RCVR terminals on the channel 2 side of the control module. Connect the shield wires to the terminals labeled SHLD.

The precautions regarding choice of transmitter probe are the same for the discharge side as for the infeed. See above.

4. Connect the SNGL, DBL, NO TAB, TAB, and FLT (fault) outputs to the system controller and/or interlocking circuitry as required. These outputs may be sinking or sourcing as determined by the setting of SW 5. See setting switch options (page 6).

The FLT outputs are always ON for no fault. The active states of the other outputs may be affected by the setting of the compatibility DIP switch as described later in this document. The outputs should not be wired to each other.

5. If calibration is to be activated remotely, connect the CAL+ and CAL- inputs appropriately. Connect a *sinking* driver or contact to the CAL- terminal and connect CAL+ to the +24V power source. Connect a *sourcing* driver to the CAL+ terminal and connect CAL- to COM.
6. If the application may involve switching between steel and aluminum blanks, the AUX inputs may be wired to provide external control of the sensing mode of the SD230. Connect a *sinking* driver or contact to the AUX- terminal and connect the AUX+ terminal to the +24V supply. Connect a *sourcing* driver to the AUX+ terminal and connect the AUX- terminal to COM.
7. If TriSense mode is to be used, connect the LH200 serial signals to the controller using the AC230-RJ breakout board and CBL230 cable. Connect the SL100 Flash Detect signal to AUX2+ if used.

Setting Switch Options

To access the DIP switches in the middle of the front panel, swing the hinged plastic window to the side. The left-most switch is SW1, the right-most is SW8. The switches are on when in the up position.

Channel 1 Switch Options

Switch	OFF	ON
SW1	Sense aluminum ends	Sense steel ends
SW2	On-press sensing	Off-press sensing (high speed)
SW3	Select fail-safe mode	Select compatibility mode
SW4	Fixed thresholds	Adjustable thresholds
SW5	Sourcing outputs	Sinking outputs
SW6	No overlap allowed	Overlap allowed if SW2 ON
SW7	Modbus Network Disabled	Modbus Network Enabled
SW8	Not used	

Channel 2 Switch Options

Switch	OFF	ON
SW1	Sense aluminum ends	Sense steel ends
SW2	Sense aluminum tabs	Sense steel tabs
SW3	Select fail-safe mode	Select compatibility mode
SW4	Fixed thresholds	Adjustable thresholds
SW5	Sourcing outputs	Sinking outputs
SW6	Enable tab profiling	Disable tab profiling
SW7	Modbus Network Disabled	Modbus Network Enabled
SW8	Not used	

NOTE: DIP switch settings are only read on power-up of the unit. After changing switch setting, power the unit down and back up again to activate the change.

Selecting Metal Types

SW1 and SW2 are used to inform the controller of the types of metals used in the manufacture of the can ends and are generally set according to the metals used. However, metals with coatings, in particular steels with coatings, may not produce significant differences in measured values between tab/no-tab and single/double conditions. In these cases, it is acceptable to select a metal setting different from the metals in use. Typically, this means, using the aluminum ends and/or tabs settings when using particular coated steels.

Sensing Aluminum Ends

When sensing aluminum ends, insure that SW1 is off for both channels.

Sensing Steel Ends

When sensing steel ends, insure that SW1 is on for both channels. See paragraph above on Selecting Metal Types.

Sensing Aluminum Tabs on Aluminum Ends

When sensing aluminum tabs on aluminum ends, insure SW1 and SW2 are off for both channels. See paragraph above on Selecting Metal Types.

Sensing Aluminum Tabs on Steel Ends

When sensing aluminum tabs on steel ends, set SW1 on and SW2 off for channel 1. See paragraph above on Selecting Metal Types.

Set SW1 on and SW2 off for channel 2.

Sensing Steel Tabs on Steel Ends

When sensing steel tabs on steel ends, set SW1 on and SW2 off for channel 1 and set both SW1 and SW2 on for channel 2. See paragraph above on Selecting Metal Types.

Set Sinking or Sourcing Outputs

The setting of SW5 determines whether the output drivers are sinking or sourcing. SW5 off selects sourcing, SW5 on selects sinking.

Set Outputs for Failsafe or Compatibility

When SW3 is on, the sourcing outputs of the SD220/SD230 provide the same logic levels as the outputs of older double shell units such as the DS33 and DS35, allowing for quick and easy retrofit installations. When SW3 is off, the output states are defined to provide maximum protection against loss of connection between the shell detector and the controlling PLC. The loss of connection is sensed as the fault condition.

The table below defines the output states for all combinations of SW3 and the possible sensing states. Also, see the SD220/230 Output Signal Drawings (page 18).

		OUTPUT STATES			
Switch	In Gap	SINGLE	DOUBLE	NO TAB	TAB
OFF	missing	OFF	ON	ON	OFF
OFF	single	ON	ON	OFF	OFF
OFF	double/tab	ON	OFF	ON	ON
ON	missing	ON	OFF	ON	OFF
ON	single	OFF	OFF	OFF	OFF
ON	double/tab	OFF	ON	ON	ON

Enable or Disable Tab Profiling

The SD220/SD230 uses two different methods for determining the absence or presence of tabs. The most basic method is simple thresholding of the sensor signals. As the shape of the beverage ends and tabs evolved and the speed of presses increased, it became necessary to implement a redundant test that recognizes the profile of a tab as it moves through the machine. This feature, however, is not compatible with larger and steel ends or with machines that have stainless steel belts. The stainless steel belts can change the sensor signal sufficiently to interfere with the tab profiling algorithm and cause the system to report self-check errors. Profiling is most effective in the detection of aluminum tabs on aluminum ends on high-speed presses. SW6 enables and disables tab profiling.

Setting Options Through the Front Panel

Set TriSense Mode (SD230 Only)

By default, the system does not enable TriSense mode (**tr**= 0). In this mode, the SD230 operates stand alone and presents Modbus entities related to its operation alone. TriSense mode is enabled by setting the **tr** setting to **1** or **2** depending on if the Flash Detect input is used. Unused, TriSense mode is **1**. Used, TriSense mode is **2**. To set the TriSense mode:

1. Press and hold the calibrate pushbutton until “**tr**” appears on the display.
2. Release the pushbutton and the display changes to “**0**”, “**1**”, or “**2**”.
3. At this point, with each press of the pushbutton the display increments up to **2** and rolling over back to **0**. The **0** disables TriSense, **1** enables TriSense without Flash Detection, and **2** enabled TriSense with Flash Detection.
4. When the desired value is on the display, wait 5 seconds and the display reverts to displaying the signal value in the selected mode.

Adjusting the Tolerance

Adjust the double shell tolerance as follows:

1. Insure that SW4 is on. If necessary, change the switch position and power the unit down and back up.
2. Press and hold the channel 1 calibrate pushbutton for at least 3 seconds until “**tL**” appears on the display.
3. Release the pushbutton and observe the current value of the threshold (in percent).
4. If the current value is ok (typically 35), wait 5 seconds and the display reverts to displaying the gauge value and retains the current tolerance.
5. To change the value, press and hold or tap the calibration pushbutton until the desired value is displayed. After the value reaches 90, it rolls over to 10 and increases.
6. When the desired value is on the display, wait 5 seconds and the display reverts to displaying the gauge value and retains the last displayed tolerance value.

Adjust the missing tab tolerance as follows:

1. Insure that SW4 is on. If necessary, change the switch position and power the unit down and back up.
2. Press and hold the channel 2 calibrate pushbutton for at least 3 seconds until “**tL**” appears on the display.
3. Release the pushbutton and observe the current value of the threshold (in percent).
4. If the current value is ok (typically 15), wait 5 seconds and the display reverts to displaying the gauge value and retains the current tolerance.
5. To change the value, press and hold or tap the calibration pushbutton until the desired value is displayed. After the value reaches 90, it rolls over to 10 and increases.
6. When the desired value is on the display, wait 5 seconds and the display reverts to displaying the gauge value and retains the last displayed tolerance value.

Set Display Direction

By default, the digital display values follow the strength of the receiver signal, increasing for stronger signal and decreasing for weaker signal. In this mode, the signal increases for thinner materials between the probes and decreases for thicker materials. The display may be inverted so that the values are proportional to material thickness rather than signal strength. To invert the display:

1. Press and hold the calibrate pushbutton until “**do**” appears on the display.

2. Release the pushbutton and the display changes to “0” or “1”.
3. At this point, with each press of the pushbutton the display toggles between “0” and “1”. The 0 selects normal display mode, 1 selects inverted mode..
4. When the desired value is on the display, wait 5 seconds and the display reverts to displaying the signal value in the selected mode.

Set Quick Calibration Changeover

When TriSense is not enabled (**tr** = 0) the AUX input may be used to quickly change between sensed metal types. When enabled (**AU=0**), the AUX input works in conjunction with SW1 (both channels) and SW2 (channel 2 only) to select the target tab and shell material combinations as presented in the Quick Calibration Changeover section below.

To change the Quick Calibration Changeover setting:

1. Press and hold the calibrate pushbutton until “AU” appears on the display.
2. Release the pushbutton and the display changes to “0” or “1”.
3. At this point, with each press of the pushbutton the display toggles between 0 and 1. The 0 enables quick changeover, 1 disables it.
4. When the desired value is on the display, wait 5 seconds and the display reverts to displaying the signal value and the parameter is saved.

Parameter Ranges

The range of values available for the SD220/SD230 adjustable parameters are as follows:

Parameter Value Ranges

ID	Function	Range of Values
tr	TriSense Operation (SD230 only)	0 No TriSense (default), 1 TriSense without Flash Detect, 2 TriSense with Flash Detect (uses AUX input)
tL	Double Tolerance	10% to 90% for double (default is 35%)
tL	Tab Tolerance	10% to 90% for tab (default is 15%)
do	Display Direction	0 for signal strength (default), 1 relative thickness
AU	Aux Metal Select	0 AUX controls sensing mode (default), 1 AUX does not control sensing mode
oL	Overlap Percentage	0% to 90% for off-press sensing only (SW2 On)
dL	Delta Tolerance	10% to 15% for off-press sensing only (SW2 On)

Special Functions

The SD220/SD230 offers two sets of optically isolated inputs on each channel that provide added control over the unit. These are the remote calibration input terminals labeled CAL+ and CAL- and the sensing mode inputs labeled AUX+ and AUX-.

CAL Input Connections

Sinking Driver:

Connect signal to CAL-, and +24V power source to CAL+

Sourcing Driver:

Connect signal to CAL+, and COM to CAL-

AUX Input Connections

Sinking Driver:

Connect signal to AUX-, and +24V power source to AUX+

Sourcing Driver:

Connect signal to AUX+, and COM to AUX-

Remote Calibration

The remote calibration inputs perform the same function as the CALIBRATE push-button switches on the front panel of the control module.

Quick Calibration Changeover

The AUX input works in conjunction with SW1 (both channels) and SW2 (channel 2 only) to select the target tab and shell material combinations as presented in the table below.

When the AUX input is activated or deactivated, the SD220/SD230 changes to accommodate the new material combination and displays, for approximately 2 seconds, a two-character abbreviation indicating the selected targeted materials. The display interpretation is as follows:

Al – aluminum tab on aluminum shell

St – steel tab on steel shell

AS - aluminum tab on steel shell

The two-character indication also displays at powerup indicating the current selection.

Channel 1 Material Selection

SW1	AUX	Shell Material
OFF	OFF	Aluminum
OFF	ON	Steel
ON	OFF	Steel
ON	ON	Aluminum

Channel 2 Material Selection

SW1	SW2	AUX	Material Combination
OFF	OFF	OFF	Aluminum tab on aluminum end
OFF	OFF	ON	Aluminum tab on steel end
OFF	ON	OFF	Aluminum tab on aluminum end
OFF	ON	ON	Steel tab on steel end
ON	OFF	OFF	Aluminum tab on steel end
ON	OFF	ON	Aluminum tab on aluminum end
ON	ON	OFF	Steel tab on steel end
ON	ON	ON	Aluminum tab on aluminum end

If quick calibration changeover is to be activated remotely, connect the AUX+ and AUX- inputs appropriately. Connect *sinking* drivers or contacts to the AUX- terminal and connect AUX+ to the +24V power source. Connect *sourcing* drivers to the AUX+ terminal and connect AUX- to COM.

Determining Firmware Version

From time to time, as improvements are made to Prime Controls products, the firmware controlling the units is revised. When setting a unit up or troubleshooting it may be necessary to determine the version number for the firmware installed in your unit. The version numbers are of the form 1.00 and are incremented either by tenths (1.01, 1.02, etc.) for small revisions or by the integer digit (1.00, 2.00, etc.) for more significant revisions.

To determine the version of the firmware running in your unit, hold the calibration pushbutton in as power is applied to the unit. The revision number is displayed directly on the digital display.

The two channels of the SD220/SD230 are independent and may be running different versions of firmware. Each must be checked separately.

MAINTENANCE

The SD220/SD230 Controller requires no periodic maintenance beyond maintaining general cleanliness of the controller, connections, and probes. Probes should be inspected and cleaned to prevent build up of ferrous particles on the sensing surfaces. The frequency of inspection depends on the operating conditions of the probes. Use a damp, not wet, cloth or sponge to clean the painted surfaces of the controller. Mild soap or detergent may also be used. Dry with a soft rag.

TROUBLESHOOTING

If the display is not on, check the +24V DC power applied to the unit. Once the display is operational, refer to displayed fault codes according to “Fault Message Interpretation” under Operation, Calibration (page 2). If the displayed values rapidly change while the machine is static, check for loose or damaged probe cables or improper routing of these cables such as routing the cables with other high voltage, or high current wires, power wires, or other noise sources.

DECOMMISSIONING

If the machine or parts of the machine have to be permanently put out of service, laws and directives in force at the time of the dismantling have to be strictly observed and complied with. In any case, check which materials can be recycled. These must be sent to an appropriate waste collecting company.

DOCUMENT APPLICABILITY

This document applies to SD220/SD230 units running firmware Version 1.11 and greater.

ELECTRICAL SPECIFICATIONS

Supply Voltage:	+24V DC plus or minus 10%
Supply Current per Channel:	130 mA plus sourcing output load
Inrush Current at Startup:	500 mA for 3 milliseconds per channel
AUX and CAL Max Input Voltage:	30V
AUX and CAL Input Impedance:	3300 ohms
Sourcing Outputs:	On voltage: Supply Voltage – 1.0 volt Off voltage: 0 volts Max current: 50 mA
Sinking Outputs:	On voltage: 0 volts Off voltage: Load pullup dependent Max current: 50 mA
Output Overload Protection:	Self-resetting thermal fuse
Input and Output Transient Protection:	30 volt transient absorber
NET Input and NET Output:	Isolated 5V half-duplex RS485 Modbus transceiver (SD230 Only)

SD220/SD230 CONTROL MODULE DIMENSIONS

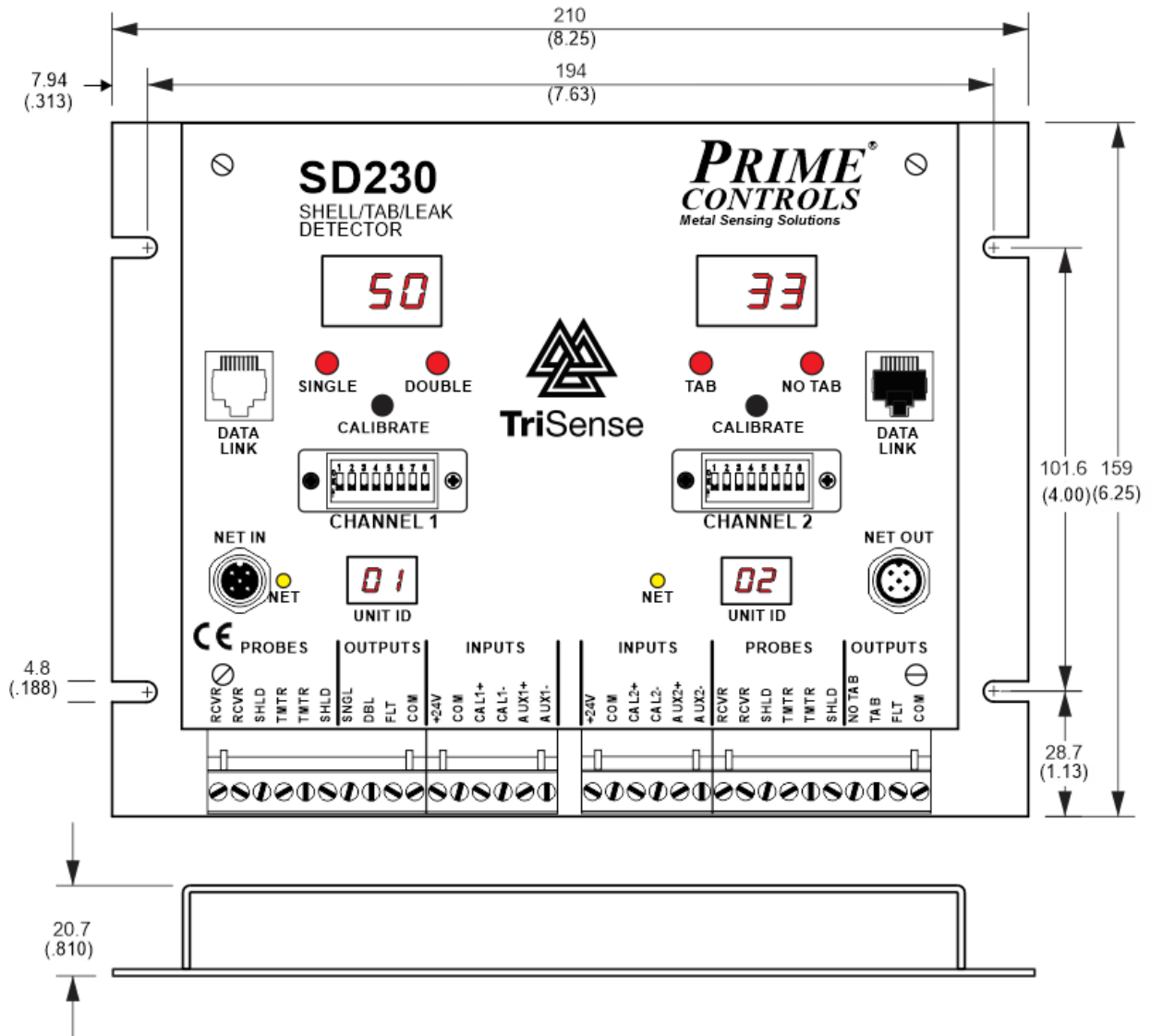

Control module dimensions are the same for the SD220 and SD230 units. Only the SD230 control module is shown.

SD230/TRISENSE WIRING DIAGRAM

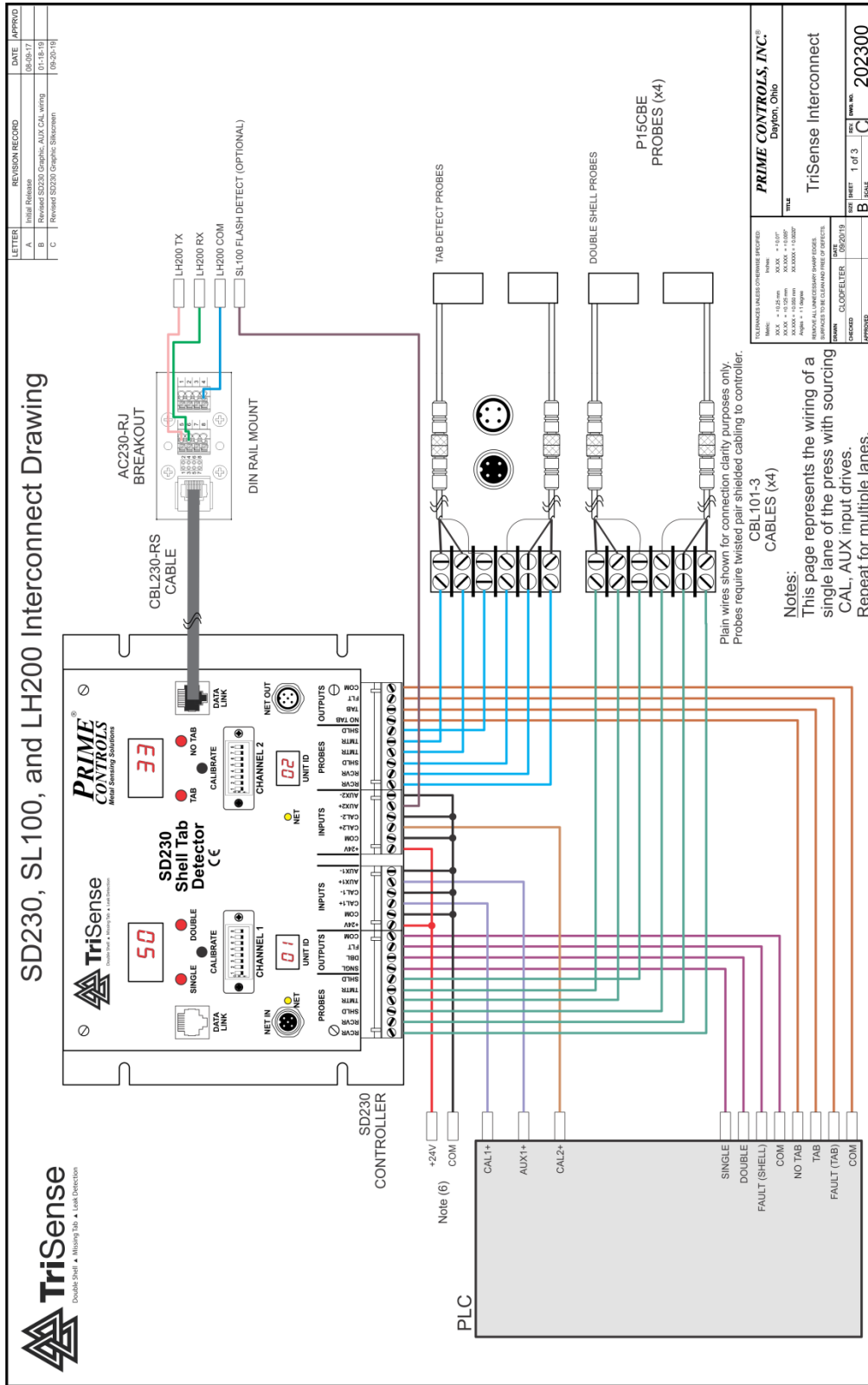

SD220/SD230 PROBE WIRING RECOMMENDATIONS

For maximum noise immunity, splice or terminate cables only when absolutely necessary. Where extension is necessary, use Belden 8761 or equivalent shielded twisted pair cable. The SD22x family of products is designed to provide high common mode noise rejection. Common mode rejection is realized most effectively with twisted pair cabling.

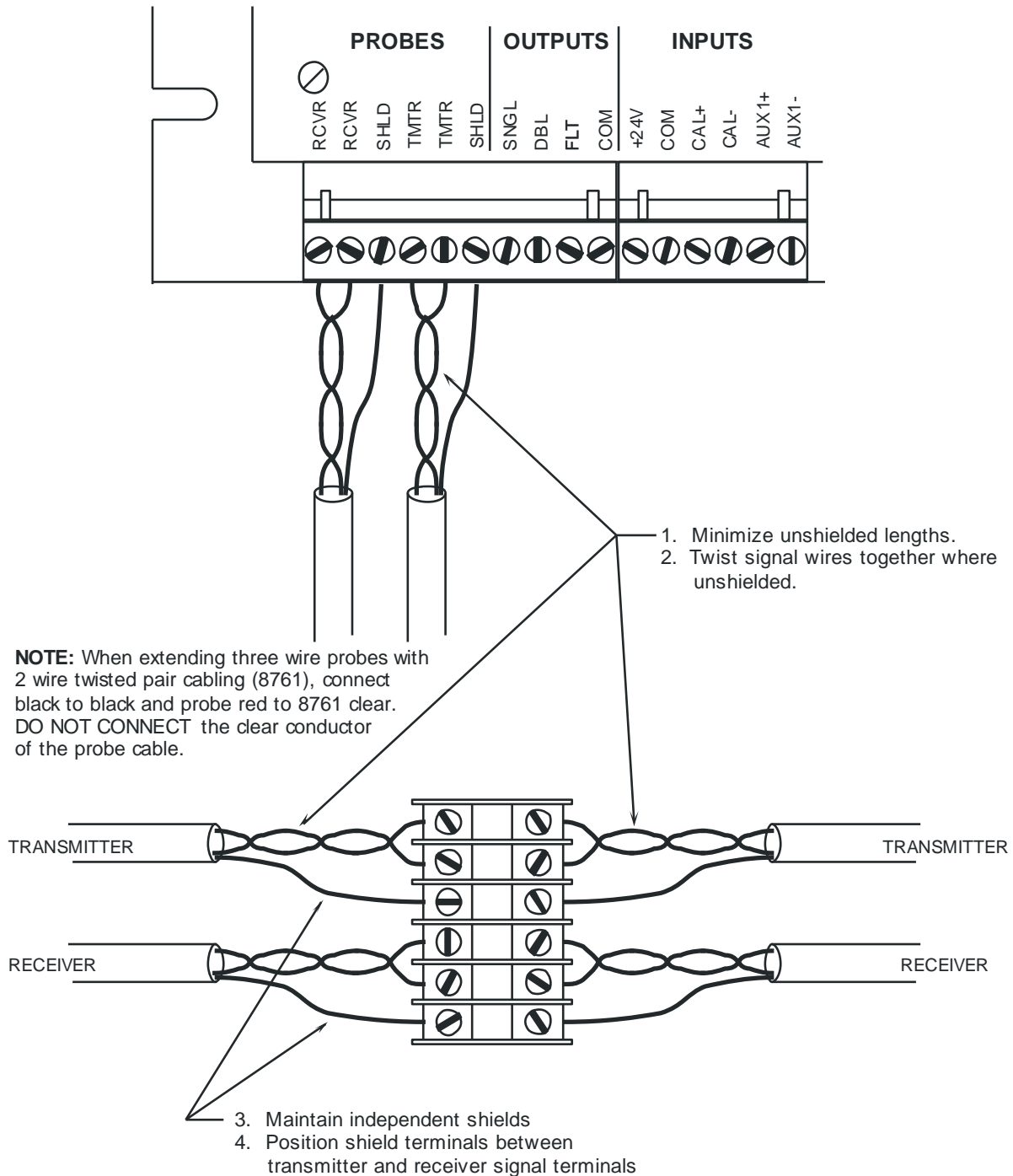

SD220/SD230 OUTPUT SIGNALS

CHANNEL 1 - INFEED

Single/Double Outputs - Failsafe Mode

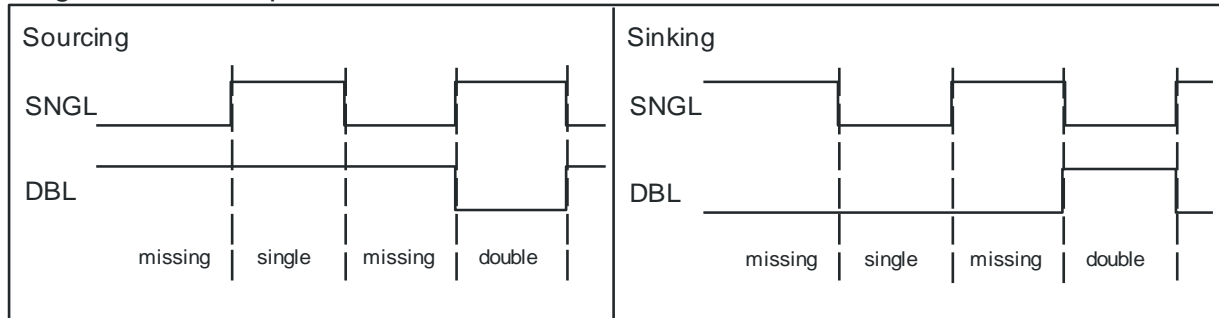

Single/Double Outputs - Compatibility Mode

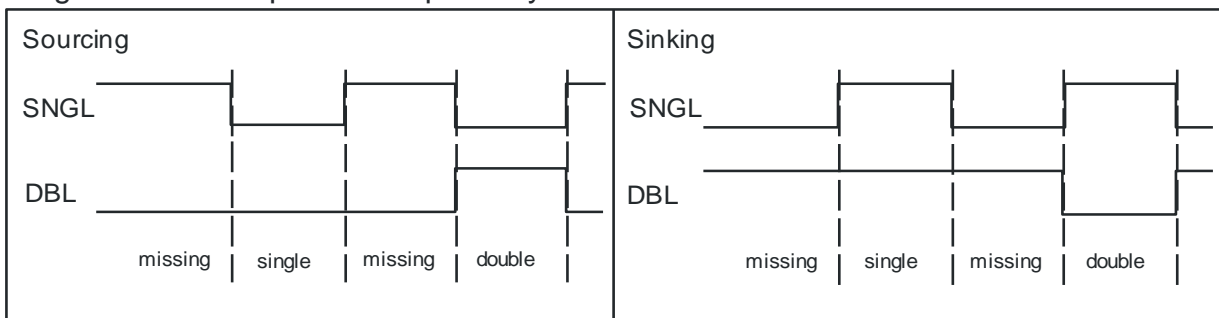

CHANNEL 2 - DISCHARGE

No Tab/Tab Outputs - Failsafe Mode

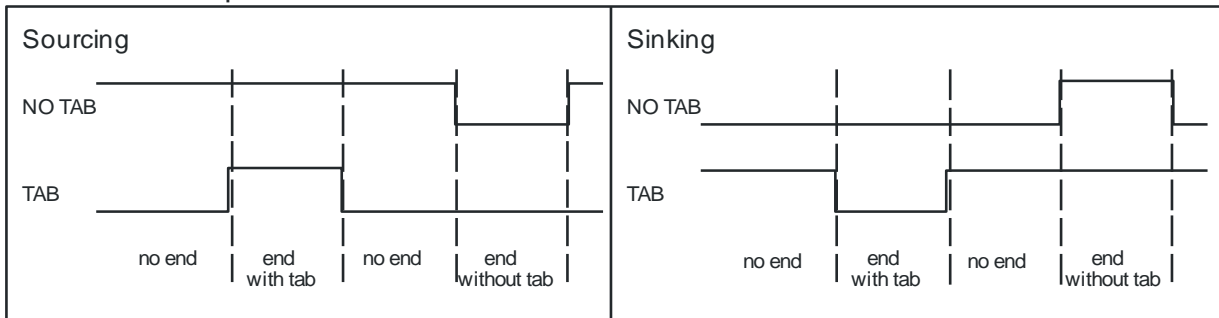

No Tab/Tab Outputs - Compatibility Mode

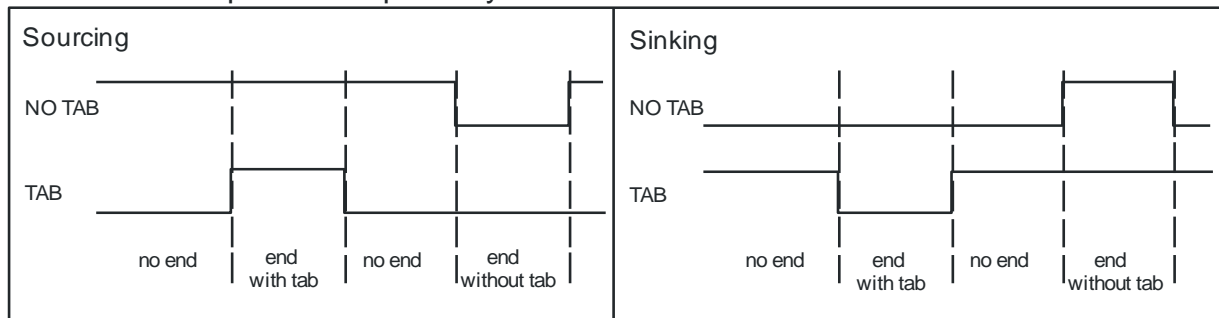

SUMMARY OF DIFFERENCES BETWEEN SD200 AND SD220/SD230

FEATURE	SD200	SD220/SD230
Wiring		
Power connection	+24V and COM to left or right channel	+24V and COM to both channels
Fault signal	Fault signals are slaved internally	Fault signals must be monitored independently and must not be wired together
AUX input frequency change	AUX inputs are slaved internally	Both AUX inputs must be driven externally
Configuration		
DIP switch access	Remove cover	Window on front panel
Number of configuration switches	Four for both channels	Eight for each channel
Sink/Source select	Jumpers beneath cover	Switch select
Al tab on steel end sensing	SU parameter set through front panel	Switch select
Profiling enable/disable	Pd parameter set through front panel	Switch select
Display inversion	Switch select	Parameter selected
Data Collection		
Serial port	Serial port	Serial port
Factory Communication		
Modbus	None	SD230 Modbus daisy chain

SD200 TO SD220/SD230 MIGRATION

Replacement of installed SD200 units by SD220/SD230s requires the following wiring changes:

1. +24V and COM must be connected to both channels of the SD220/SD230.
2. SD200 faults for either channel are reported on both fault outputs. The fault signals on the two channels of the SD220/SD230 are totally independent and must not be wired together.
3. If your installation uses the AUX input to quickly change between calibrations on different shell materials, it is necessary with the SD220/SD230 to activate the AUX input on both channels independently. The AUX inputs are not slaved together as in the SD200.

Configuration of the SD220/SD230 has been simplified as compared to the SD200. It is no longer necessary to remove the cover to change options. These changes include:

1. The DIP switches, now eight per channel instead of four per unit, are accessible through a window on the front panel.

2. Where the SD200 requires jumper changes under the front panel to select sinking or sourcing outputs, the selection on the SD220/SD230 is made through the setting of DIP switch 5. Set SW5 off for sourcing and on for sinking.

The method of setting some options has changed. The list below shows which settings remain the same and which have changed:

CHANNEL 1 Configuration Switches		
SW1	(No change)	Configures the unit for aluminum or steel ends
SW2	(Change)	No longer inverts display, must be off on SD230
SW3	(No change)	Selects output failsafe or compatibility mode
SW4	(No change)	Selects fixed thresholds or adjustable thresholds
SW5	(New)	Selects sourcing or sinking outputs
SW6	(New)	Allows or disallows overlap - not used on SD230
SW7	(New)	Enables or disables Modbus Network communications
SW8	Not used	
CHANNEL 2 Configuration Switches		
SW1	(No change)	Configures the unit for aluminum or steel ends
SW2	(Change)	Selects tab material, off for aluminum, on for steel
SW3	(No change)	Selects output failsafe or compatibility mode
SW4	(No change)	Selects fixed thresholds or adjustable thresholds
SW5	(New)	Selects sourcing or sinking outputs
SW6	(New)	Enables or disables tab profiling
SW7	(New)	Enables or disables Modbus Network communications
SW8	Not used	

Modbus Network communication is only available on the SD230 unit.

Setup parameter “**SU**” not available on SD230; use SW2.

Setup parameter “**Pd**” not available on SD230; use SW6.

SW2 no longer inverts the display as on the SD220/SD230; use setup parameter “**do**” (display option) on the SD220/SD230.

MODBUS NETWORK (SD230 Only)

Description

The SD230 features network communications capability, either directly over Modbus to a Pro-face HMI or indirectly through a gateway (ET230) to Ethernet/IP connected PLCs and HMIs. The network connection provides access to all status information from the SD230, allows for remote activation of the calibrate function, and if TriSense mode is enabled, full access to LH200 configuration, operation, and result data. Additionally, diagnostic functions may be invoked and profiles of tested shells may be displayed.

The SD230 units, when daisy-chained on the Modbus network, automatically assign their own device ID numbers starting with 01 for the left channel of the unit connected to the HMI or gateway, through N for the right channel of the last unit in the chain. For a four-out press, the assigned IDs would be from 01 through 08. The device ID appears on the two-digit display in the lower half of the front panel of the SD230.

The bicolor LEDs located adjacent to the network connectors on the SD230, indicate status of the communication with the channel on which they appear. The LED flashes yellow when a packet is received and green when a packet is transmitted and a momentary red when a CRC or bad function error occurs.

For details of Pro-face HMI operation see SD230 Pro-face HMI User Instructions.

Installation

Standard five conductor M12 male-female cables are used to daisy-chain from one SD230 unit to the next. The daisy-chain cables are typically Prime Controls part number CBL112-1 for 0.3 meter or CBL112-2 for 2 meters. The cable requirement to the left channel of the lead unit depends upon the device being connected. The figures that follow show the cable required from the SD230 to a Pro-face HMI and from the SD230 to the ET230 gateway. Part number choices for the SD230 to Pro-face HMI cable are CBL230-HMI-2 (2 meter, no field attachable connectors), or a CBL230-HMI-X-FA with field attachable M12 connectors for easier routing through conduits. The -X- is ordered as a 2, 5, or 10 for convenient lengths in meters.

Setup

Setup of the SD230 units for networking requires only that DIP SW7 is ON when the units are powered up and that the appropriate five conductor cables connect all units in a daisy-chain configuration. When setup is complete, at power up the units display their ID numbers from 01 to 2xN where N is the number of SD230 units connected together.

TriSense functionality requires wiring the LH200 serial signals to the SD230 via the AS230-RJ breakout board and CBL230 cable. Optionally, the SL100 Flash Detect signal may be connected to the AUX2+ input of the SD230 for confirmation of SL100 operation as well.

Cabling

SD230/Pro-Face System Cabling

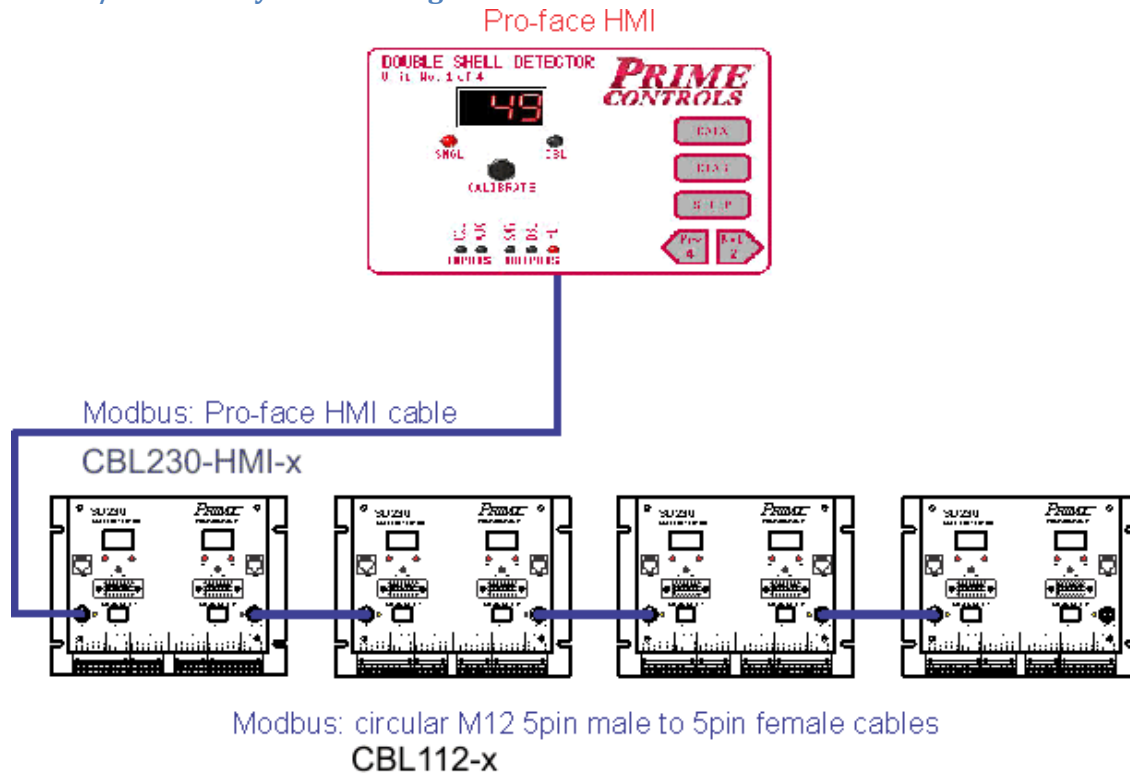

SD230 To Pro-Face HMI Cable

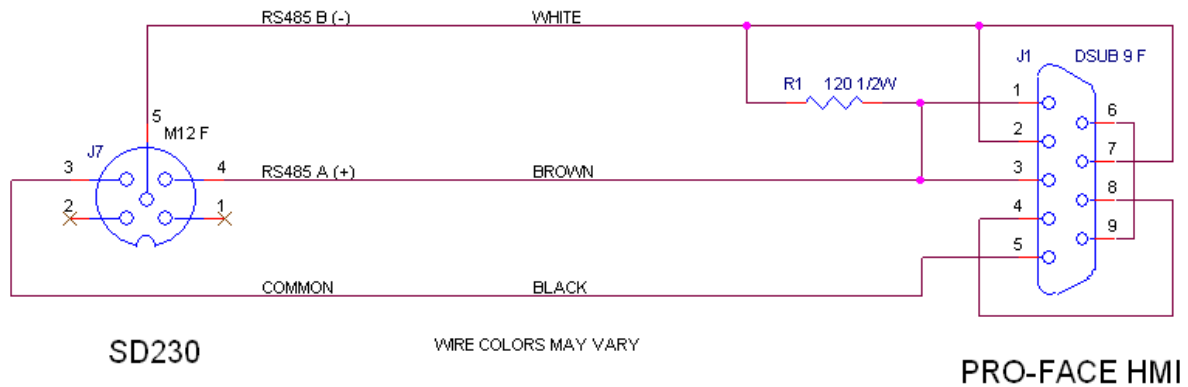

EthernetIP Gateway Interconnect



SD230, SL100, and LH200 Interconnect Drawing

LETTER	REVISION RECORD	DATE	APPROV

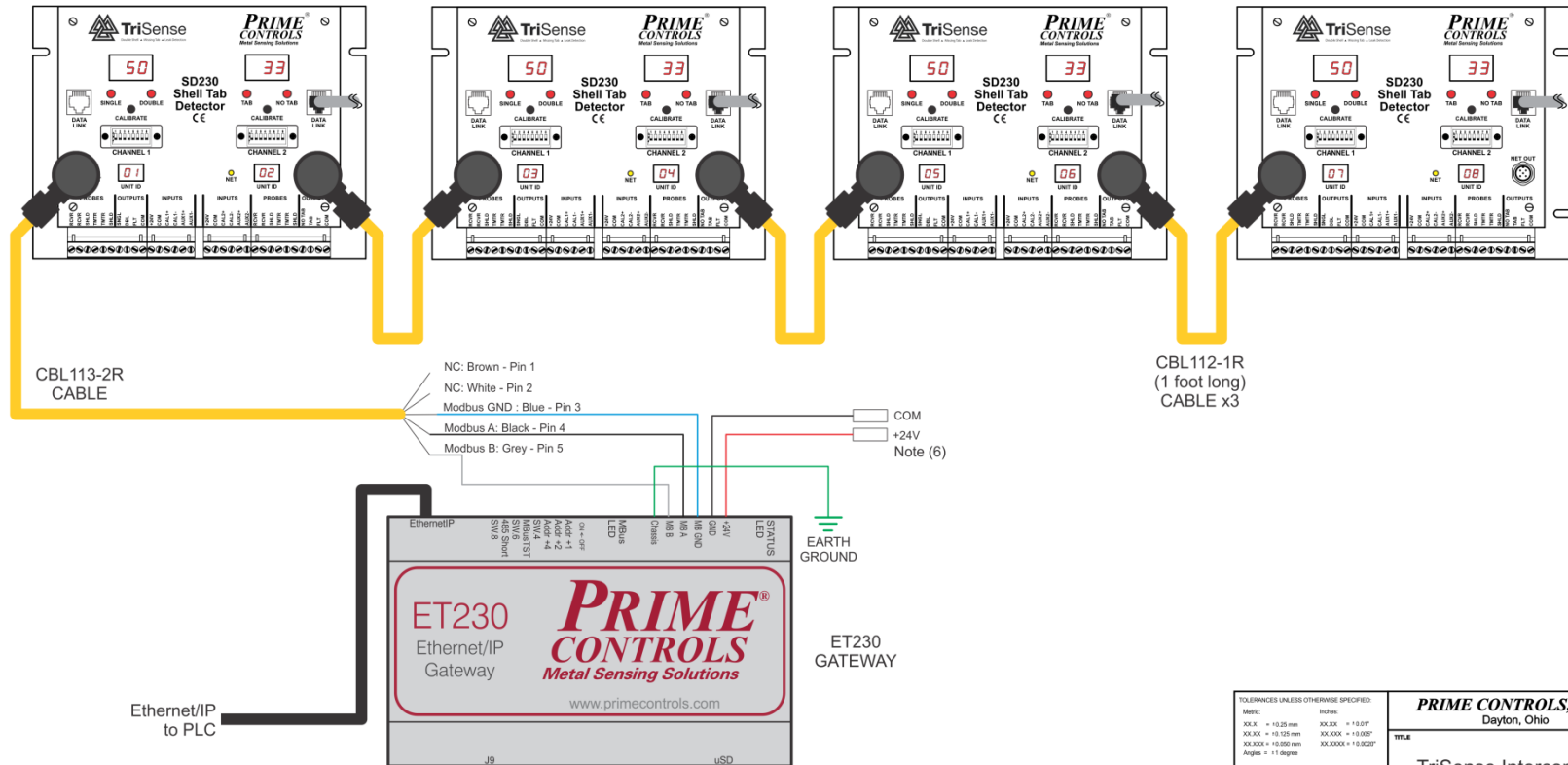

<small>TOLERANCES UNLESS OTHERWISE SPECIFIED:</small> Metric: Inches XX.X = +0.25 mm XX.XX = +0.01" XX.XX = +0.125 mm XX.XXX = +0.005" XX.XXX = +0.050 mm XX.XXXX = +0.002" Angles = ± 1 degree		PRIME CONTROLS, INC.[®] Dayton, Ohio	
TITLE TriSense Interconnect			
DRAWN: CLODFELTER CHECKED: APPROVED:	DATE: 09/20/19	SHEET: 3 of 3 SCALE:	REV: C DWG. NO.: 202300

J1 is a 6 pin right angle male header (part number 1803316) that mates with a removable 5 pin straight female plug (part number 1803617) to allow for easy screw in/out of discrete wires (14 to 24 AWG) in the field. The first section of J1 is for power. The second section of J1 is for the RS485 interconnect cable to the SD230.

Gateway	Description	
J1.1	+24V input; 1Amax; 5Vmin to 30Vmax operating range	
J1.2	GND; Power return	
J1.6	Chassis; tie this pin to earth ground	
	TriSense NET IN	Color - Description
J1.3	3	Blue - Modbus_Gnd; Ground reference for the Isolated Modbus 485 transceiver; the Modbus_Gnd must be connected to the ground of the SD230 transceiver
J1.4	4	Black - MODBUS_A; bidirectional 485 data pin
J1.5	5	Gray - MODBUS_B; bidirectional 485 data pin
	1,2	No connect

The TriSense CHANNEL 1 NET IN cable is a circular M12 cable 5pin female to wire leads pigtail with a typical part number of 1838361-X (straight) or 1682980 (right angle) for long shielded cables. Prime Controls cables CBL113-2 (straight) or CBL113-2R (right angle) may be used for unshielded cables less than 2 meters in length when the ET230 and SD230 are in the same cabinet. Figure 3 shows the male M12 connector pin positions looking down on the SD230 NET IN connector.

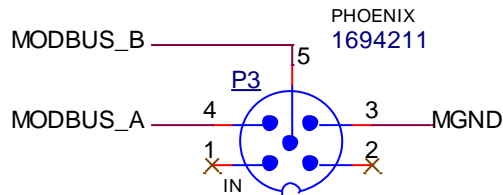

Figure 3

ModBus Entities

Entities listed in cyan are native to the SD230 controller are always available. Entities listed in orange are available in the TriSense configuration when an LH200 is attached to the SD230 controller's serial input and TriSense is enabled.

All ET230 Tags must be prefaced with Prime_RdChn[index] or Prime_WrChn[index] where index is the channel number (1-8).

Prime_RdChn[index] is used for reading the respective tags while Prime_WrChn[Index] is used to trigger a write operation to R/W tags. To read the LeftLED of channel 3, one uses tag Prime_RdChn[3].BitGroup1,FrontPanel.0.

Discrete Coil Outputs (000001) (Read/Write)

Entity Number	ET230 Tags	Name	Meaning
000001	BitGroup1.FrontPanel.0	LeftLED	Single/No-Tab LED
000002	BitGroup1.FrontPanel.1	RightLED	Double/Tab LED
000003	BitGroup1.FrontPanel.2	Single/No-Tab	Single/No-Tab Output
000004	BitGroup1.FrontPanel.3	Double/Tab	Double/Tab Output
000005	BitGroup1.FrontPanel.4	Fault	Fault Output
000006	BitGroup1.FrontPanel.5	TxProbeFault	Transmitter Probe Fault
000007	BitGroup1.FrontPanel.6	RxProbeFault	Receiver Probe Fault
000008	BitGroup1.FrontPanel.7	VelocityFault	Shell Velocity Fault (SD235 only)
000009	BitGroup1.HMIControls.0 & CalValue & CalStrobe	NetCalReq	Calibration request from HMI
000010	BitGroup1.HMIControls.1 & ForceHighOutputsValue & ForceHighOutputsStrobe	ForceHighOutputs	Force all outputs high from HMI
000011	BitGroup1.HMIControls.2 & ForceLowOutputsValue & ForceLowOutputsStrobe	ForceLowOutputs	Force all outputs low from HMI
000012	BitGroup1.HMIControls.3	NetFreezeScan	Freeze Scan Control Bit

Entity Number	ET230 Tags	Name	Meaning
000013	N/A	Reserved	
000014	N/A	Reserved	
000015	N/A	Reserved	
000016	N/A	Reserved	
000017	BitGroup3.LH200_IO.0 & FreeRunValue & FreeRunStrobe	Free Run	LH200 – Freerun Mode
000018	BitGroup3.LH200_IO.1 & AutoAdjustValue & AutoAdjustStrobe	Auto Adjust (Bias)	LH200 – Auto Adjust Bias Mode
000019	BitGroup3.LH200_IO.2 & CalOffsetValue & CalOffsetStrobe	Cal Offset	LH200 – Trigger Calibrate Offset Adjustment
000020	N/A	Unhide Reports	LH200 – Unhide reports mask
000021	N/A	Reserved	LH200 – Reports Flag (B0)
000022	N/A	Result Flags	LH200 – Reports Flag (B1)
000023	N/A	Temperature	LH200 – Reports Flag (B2)
000024	N/A	Leak Factor	LH200 – Reports Flag (B3)
000025	N/A	Peak Value	LH200 – Reports Flag (B4)
000026	N/A	Sample Sum	LH200 – Reports Flag (B5)
000027	N/A	Sample High Value	LH200 – Reports Flag (B6)
000028	N/A	Sample Count	LH200 – Reports Flag (B7)
000029	N/A	Segment Count	LH200 – Reports Flag (B8)
000030	N/A	Dark Spread	LH200 – Reports Flag (B9)
000031	N/A	Dark Max	LH200 – Reports Flag (B10)
000032	N/A	Dark Min	LH200 – Reports Flag (B11)
000033	N/A	Dark Average	LH200 – Reports Flag (B12)
000034	N/A	DAC	LH200 – Reports Flag (B13)
000035	N/A	Dark Ref Slow Average	LH200 – Reports Flag (B14)

Entity Number	ET230 Tags	Name	Meaning
000036	N/A	Dark Ref Fast Average	LH200 – Reports Flag (B15)

Discrete Coil Inputs (100001) (Read Only)

Entity Number	ET230 Tags	Name	Meaning
N/A	Prime_ModbusFault	Modbus Fault	Modbus Fault detected by PLC (PLC tag)
100001	BitGroup2.DIPsw.0	DIPSw1	DIP Switch 1 input
100002	BitGroup2.DIPsw.1	DIPSw2	DIP Switch 2 Input
100003	BitGroup2.DIPsw.2	DIPSw3	DIP Switch 3 input
100004	BitGroup2.DIPsw.3	DIPSw4	DIP Switch 4 input
100005	BitGroup2.DIPsw.4	DIPSw5	DIP Switch 5 input
100006	BitGroup2.DIPsw.5	DIPSw6	DIP Switch 6 input
100007	BitGroup2.DIPsw.6	DIPSw7	DIP Switch 7 input
100008	BitGroup2.DIPsw.7	DIPSw8	DIP Switch 8 input
100009	BitGroup2.SD230_IO.0	InputReg1	Calibrate pushbutton input
100010	BitGroup2.SD230_IO.1	InputReg2	External CAL input
100011	BitGroup2.SD230_IO.2	InputReg3	AUX input
100012	BitGroup2.SD230_IO.3	RunFlag	Machine is running flag
	N/A	Reserved	
100018	BitGroup4.LH200_IO.0	Cal Fail	Indicates LH200 was unable to calibrate
100019	BitGroup4.LH200_IO.1	Cal Busy	Indicates LH200 is busy with calibration
100020	BitGroup4.LH200_IO.2	LH200 Online	LH200 – Indicates that an LH200 is connected and communicating
100021	BitGroup4.LH200_IO.3	Freerun Mode Active	LH200
100022	BitGroup4.LH200_IO.4	TriSense	SD230 Parameter Setting
100023	BitGroup4.LH200_IO.5	Flash Detect Input	SD230 Parameter Setting

Entity Number	ET230 Tags	Name	Meaning
100024	BitGroup4.LH200_IO.6	Machine Running Flag	LH200
100025	N/A	Unhide Report parameters	LH200
100026	BitGroup5.LH200_IO.0	Peak Value Exceeded Flag (L)	LH200 – Result Flag
100027	BitGroup5.LH200_IO.1	Dark Spread Fail Flag (N)	LH200 – Result Flag
100028	BitGroup5.LH200_IO.2	Dark Level Fail Flag (D)	LH200 – Result Flag
100029	BitGroup5.LH200_IO.3	Flash Detect Flag (F)	LH200 – Result Flag + AUX Input
100030	BitGroup5.LH200_IO.4	Flash Detect Valid Flag (K)	LH200 – Result Flag + AUX Input

The result flags are also readable in a packed binary form as a Register Input.

Register Inputs (300001) (Read Only)

Entity Number	ET230 Tags	Name	Meaning
300001		NetworkID	Modbus network ID (1-32)
300002	GageAttrFlag	GageAttrFlag	Gauging attributes
300003	MaterialCode	MaterialCode	Shell and tab material code
300004	ScaledGageDispVal	ScaledGageDispVal	Gage value (0 to 255)
300005	FaultReg	FaultReg	Fault reporting register
300006	WatchdogCounter	WatchdogReg	Watchdog counter register
300007	NuOfChan	NodeCt	Count of SD units on the network
300008			Not used
300009			Not used
300010	SwLabels[0]	SwLabel1	DIP Switch 1 label text (Packed Bytes)
300020	SwLabels[1]	SwLabel2	DIP Switch 2 label text (Packed Bytes)
300030	SwLabels[2]	SwLabel3	DIP Switch 3 label text (Packed Bytes)
300040	SwLabels[3]	SwLabel4	DIP Switch 4 label text (Packed Bytes)
300050	SwLabels[4]	SwLabel5	DIP Switch 5 label text (Packed Bytes)
300060	SwLabels[5]	SwLabel6	DIP Switch 6 label text (Packed Bytes)
300070	SwLabels[6]	SwLabel7	DIP Switch 7 label text (Packed Bytes)
300080	SwLabels[7]	SwLabel8	DIP Switch 8 label text (Packed Bytes)
300091	ProfileSize	ProfileSize	Number of data points in the profile

Entity Number	ET230 Tags	Name	Meaning
N/A	Prime_ProfileEnableChn	Profile Channel Select	Selects channel for active profile capture (PLC tag)
300092	ProfileData & Prime_ProfileEnableChn	ProfileData	Data buffer (200 packed bytes read as 100 16 bit registers), data set selected by ProfileIndex
300292	N/A	FirmwareVersion	Firmware version no (dd.dd x 100)
	N/A	Reserved	
300300	N/A	LH200 Firmware Version	LH200 Firmware version no (dd.dd x 100)
N/A	Prime_LH200ReportEnableChn	Report Channel Select	Selects channel for active report capture (PLC tag)
N/A	Prime_LH200ReportIndex	Report Index Select	Selects report # for active report capture (PLC tag) – Allows PLC to select between reports N to N-7 below. (Range: 0-7)
Start of table of 8 LH200 reports			
300301	LH200_Report.Report[0] & Prime_ReportEnableChn & Prime_ReportIndex	Report Number	LH200 – Atomic Read (modulo 32768)
300302	LH200_Report.Report[1] & Prime_ReportEnableChn & Prime_ReportIndex	Dark Ref Fast Average	LH200 – Atomic Read
300303	LH200_Report.Report[2] & Prime_ReportEnableChn & Prime_ReportIndex	Dark Ref Slow Average	LH200 – Atomic Read
300304	LH200_Report.Report[3] & Prime_ReportEnableChn & Prime_ReportIndex	DAC	LH200 – Atomic Read
300305	LH200_Report.Report[4] & Prime_ReportEnableChn & Prime_ReportIndex	Dark Average	LH200 – Atomic Read
300306	LH200_Report.Report[5] &	Dark Min	LH200 – Atomic Read

Entity Number	ET230 Tags	Name	Meaning
	Prime_ReportEnableChn & Prime_ReportIndex		
300307	LH200_Report.Report[6] & Prime_ReportEnableChn & Prime_ReportIndex	Dark Max	LH200 – Atomic Read
300308	LH200_Report.Report[7] & Prime_ReportEnableChn & Prime_ReportIndex	Dark Spread	LH200 – Atomic Read
300309	LH200_Report.Report[8] & Prime_ReportEnableChn & Prime_ReportIndex	Segment Count	LH200 – Atomic Read
300310	LH200_Report.Report[9] & Prime_ReportEnableChn & Prime_ReportIndex	Sample Count	LH200 – Atomic Read
300311	LH200_Report.Report[10] & Prime_ReportEnableChn & Prime_ReportIndex	Sample High Value	LH200 – Atomic Read
300312	LH200_Report.Report[11] & Prime_ReportEnableChn & Prime_ReportIndex	Sample Sum	LH200 – Atomic Read
300313	LH200_Report.Report[12] & Prime_ReportEnableChn & Prime_ReportIndex	Peak Value	LH200 – Atomic Read
300314	LH200_Report.Report[13] & Prime_ReportEnableChn & Prime_ReportIndex	Leak Factor	LH200 – Atomic Read
300315	LH200_Report.Report[14] & Prime_ReportEnableChn & Prime_ReportIndex	Temperature	LH200 – Atomic Read

Entity Number	ET230 Tags	Name	Meaning
300316	LH200_Report.Report[15] & Prime_ReportEnableChn & Prime_ReportIndex	Result Flags	LH200 – Atomic Read + Synth AUX bits
300317-332	N/A – Use Prime_ReportIndex to select.	Report (N-1)	LH200 – Atomic Read
300333-348	N/A – Use Prime_ReportIndex to select.	Report (N-2)	LH200 – Atomic Read
300349-364	N/A – Use Prime_ReportIndex to select.	Report (N-3)	LH200 – Atomic Read
300365-380	N/A – Use Prime_ReportIndex to select.	Report (N-4)	LH200 – Atomic Read
300381-396	N/A – Use Prime_ReportIndex to select.	Report (N-5)	LH200 – Atomic Read
300397-412	N/A – Use Prime_ReportIndex to select.	Report (N-6)	LH200 – Atomic Read
300413-428	N/A – Use Prime_ReportIndex to select.	Report (N-7)	LH200 – Atomic Read
300429	N/A	DIAG Missed Reports	SD230 Diagnostic Counters
300430	N/A	DIAG Bad Shifts	SD230 Diagnostic Counters
300431	N/A	DIAG Bad CRC	SD230 Diagnostic Counters
300432	N/A	DIAG Pending	SD230 Diagnostic Counters
300433	N/A	DIAG Double Pending	SD230 Diagnostic Counters
300434	N/A	DIAG Partial Messages	SD230 Diagnostic Counters
300435	N/A	DIAG Fails	SD230 Diagnostic Counters
300436	N/A	DIAG Retries	SD230 Diagnostic Counters
300437	N/A	DIAG Bad CRC	LH200 Diagnostics Counters
300438	N/A	DIAG Short Msg	LH200 Diagnostics Counters
300439	N/A	DIAG Fails	LH200 Diagnostics Counters
300440	N/A	DIAG Retries	LH200 Diagnostics Counters

All values listed with “Atomic Read” are to be read as a single block. They use a data locking mechanism in the SD230 code to prevent update to these values once a read is initiated and until it is completed for all parameters.

Reports are read by setting two tags: Prime_ReportEnableChn which selects the channel from which to read, and Prime_ReportIndex which selects which of the eight reports stored in the SD230 is read. Prime_ReportIndex = 0 selects the most recent report while Prime_ReportIndex = 7 selects the seventh most recent. Acceptable values for Prime_ReportIndex are 0 through 7.

Report number is a modulo 32768 count of the reports sent by the LH200. This count originates in the LH200 and is used to detect dropped/missing reports by the application program. When the LH200 online coil is zero, the report number shall be set to 65535 to indicate the report parameters may be invalid.

Interpretation of the Gage Attrb Flag 300002

Result Flags	Parameter
B0..B2	Gage Type Code 0 -> Single/Double Detection 1 -> On-Press Tab Detection 2 -> Off-Press Tab Detection
B3	Tolerance Adjustment Allowed
B4	Overlap Adjustement Allowed
B5	Delta Adjustment Allowed

Interpretation of the LH200 Result Flag 300316

Result Flags	Parameter
B0	Dark Level Fail (D)
B1	Dark Spread Fail (N)
B2	Peak Value Exceeded (L) [light leak]
B3	Flash Detect (F) [SL100 strobe]
B4	Flash Detect Valid (K) [SL100 strobe]

D – Average dark current exceeded the dark limit, Bit 0

N – dark spread exceeded the spread limit, Bit 1

L – peak value exceeded the leak limit, Bit 2

F – Flash pulse detected, Bit 3

K – Flash pulse detection bit is valid. It is possible that a report from the LH200 is delayed due to retries. In this case, the timing of the report message may prevent proper sampling of the AUX input. In this case, this bit is set to zero and the validity of the flash detection bit cannot be determined.

Holding Registers (400001) (Read/Write)

Entity Number	ET230 Tags	Name	Meaning
400001	GageTolRd & GageTolValue & GageTolStrobe	GageTol	Gauging tolerance in percent
400002		Delta	Minimum panel to tab delta (SD225 only)
400003	OverlapPercentage	Overlap	Off-press shell overlap allowance in percent
400004	DataInvertContrlRd & DataInvertControlValue & DataInvertControlStrobe	DisplayInv	Display invert (100 to 0 vs 0 to 100)
400005	SD230Gain	Gain	Receiver gain (0 to 255)
400006	GageThreshold	GageThreshold	Single to double or tab to no-tab threshold
400007	GapThresh	GapThresh	Shell to no shell data threshold
400008	DAcqGadThresh & DAcqGapThreshValue & DAcqGapThreshStrobe	DAcqGapThresh	Shell/no-shell threshold for data acquisition
400009	Frequency	Frequency	Transmitter frequency
400010			Not used
400011	TotalMsgCnt & ClearDiagStrobe	BusMsgCt	Modbus total message count
400012	HandledMsgCnt & ClearDiagStrobe	HandledMsgCt	Modbus handled message count
400013	CRCErrCnt & ClearDiagStrobe	CRCErrCt	Modbus CRC error count
400014	ExceptionMsgCnt & ClearDiagStrobe	ExceptionCt	Modbus exception response count
400015	NoResponseMsgCnt & ClearDiagStrobe	NoRespCt	Modbus no-response count
400016	CharOverrunCnt & ClearDiagStrobe	CharORCt	Modbus character overrun count

Entity Number	ET230 Tags	Name	Meaning
400017	NAKresponseCnt & ClearDiagStrobe	NAKRespCt	Modbus NAK response count
400018	BusyResponseCnt & ClearDiagStrobe	BusyRespCt	Modbus busy response count
400019	ProfileIndex & ProfileIndexValue & ProfileIndexStrobe	BufferIndex	Profile index for retrieval of current and past profiles: 0 to 9, 0 is most recent
	N/A	Reserved	
400030	LH200DrkLimit & LH200DrkLimitValue & LH200DrkLimitStrobe	Dark Limit	LH200 (1-4000, 30 default)
400031	LH200Gain & LH200GainValue & LH200GainStrobe	Gain Value	LH200 (10-100, default 100)
400032	LH200LeakLimit & LH200LeakLimitValue & LH200LeakLimitStrobe	Leak Limit	LH200 (1-4000, 500 default)
400033	LH200SprdLimit & LH200SprdLimitValue & LH200SprdLimitStrobe	Spread Limit	LH200 (1-4000, 500 default)
400034	LH200Bias & LH200BiasValue & LH200BiasStrobe	Bias	LH200 (1-100, 30 typical)

In cases where three PLC tags are listed as in: GageToIRd & GageToIValue & GageToIStrobe. The first PLC tag (GageToIRd) is the current value of this parameter in the SD230 or LH200. The second PLC tag (GageToIValue) is the value that will be written to the SD230/LH200 when the third value (GageToIStrobe) is set to minus one (-1). The third tag is set to zero upon completion of the writing action.

In cases where two PLC tags are listed as in: TotalMesageCnt & ClearDiagStrobe. The first PLC tag (TotalMesageCnt) is the current value of this parameters in the SD230 or LH200. The second PLC tag (ClearDiagStrobe) is set to minus one (-1) to reset the associated value(s) to zero (TotalMesageCnt). This tag is set to zero upon completion of the clear action.

In cases where one PLC tag is listed, setting or clearing mechanisms have not been implemented for the PLC and the value is effectively read only.

LIMITATION AND EXCLUSION OF WARRANTIES

All goods purchased from PRIME CONTROLS, INC. shall be free from defects in materials, design and workmanship under normal conditions of use for one year from the date of shipment. THIS WARRANTY IS THE SOLE WARRANTY AND IS EXPRESSLY IN LIEU OF ALL OTHER WARRANTIES, EXPRESS OR IMPLIED, INCLUDING BUT NOT LIMITED TO ANY IMPLIED, WARRANTY OF MERCHANTABILITY OF FITNESS FOR A PARTICULAR PURPOSE. THE LIABILITY OF PRIME CONTROLS TO ANY PURCHASER SHALL BE LIMITED EXCLUSIVELY TO THE COST OF REPLACEMENT OR REPAIR OF DEFECTIVE PARTS, AND SHALL NOT INCLUDE LIABILITY FOR ANY DIRECT, CONSEQUENTIAL OR INCIDENTAL DAMAGES WHATSOEVER, WHETHER FORESEEN OR UNFORESEEN, INCLUDING BUT NOT LIMITED TO LOST PROFITS, LOST SALES, OR INJURY TO PERSONS OR PROPERTY.

NAME PLATE INFORMATION

Prime Controls, Inc.

4528 Gateway Circle

Dayton, OH 45440-1712

USA

Shell/Tab Detector

Model: SD220/SD230

+24V DC @ 500mA per channel



EC DECLARATION OF CONFORMITY

PRIME CONTROLS, INC.

4258 Gateway Circle
Dayton, OH 45440
USA

Name and address of the company established in European Community and authorized to compile the Technical File:

ACC - Services Contact
78 Allée Primavera
Centre Ubidoca 2402
74370 Annecy
FRANCE

PRIME CONTROLS, INC. declares under our sole responsibility that the product described as:

Equipment Name: Shell / Tab Detector
Generic Equipment Description: Used to detect defects on conversion presses
Model /Type: SD220 SD230

Complies with the requirements of the following European Union Directives:

Machinery Directive 2006/42/EC
Radio Equipment Directive 2014/53/EU
RoHS Directive 2011/65/EU

Main standards considered:

EN ISO 12100:2010
EN 61010: 2010
EN 50364: 2010
EN 301-489-1 V2.1.1, EN 301 489-3 V2.1.0
EN 300 330 V2.1.0
EN 50581:2012

Date: December 9, 2020 At: Dayton, Ohio USA

Name of authorized company representative: Ms. Beth Graves, President

Signature: Beth Graves {Electronic Signature}

UKCA DECLARATION OF CONFORMITY

PRIME CONTROLS, INC.

4258 Gateway Circle
Dayton, OH 45440
USA

Name and address of the company established in European Community and authorized to compile the Technical File:

ACC - Services Contact
International House
10 Churchill Way
Cardiff CF10 2HE
UNITED KINGDOM

PRIME CONTROLS, INC. declares under our sole responsibility that the product described as:

Equipment Name: Shell / Tab Detector
Generic Equipment Description: Used to detect defects on conversion presses
Model /Type: SD220 SD230

Complies with the requirements of the following European Union Directives:

The Supply of Machinery (Safety) Regulations 2008
The Radio Equipment Regulations 2017
The Restriction of the Use of Certain Hazardous Substances in Electrical and Electronic Equipment Regulations 2012

Main standards considered:

BS EN ISO 12100:2010
BS EN 61010: 2010
BS EN 50364: 2010
BS EN 301-489-1 V2.1.1, BS EN 301 489-3 V2.1.0
BS EN 300 330 V2.1.0
BS EN 50581:2012

Date: December 9, 2020 At: Dayton, Ohio USA

Name of authorized company representative: Ms. Beth Graves, President

Signature: Beth Graves {Electronic Signature}